



Invacare® Spectra XTR Series

en **Power Wheelchair
User Manual**



This manual **MUST** be given to the user of the product.
BEFORE using this product, read this manual and save for future reference.



Yes, you can.®

© 2017 Invacare Corporation

All rights reserved. Reproduction, duplication or modification in whole or in part is prohibited without prior written permission from Invacare. Trademarks are identified by ™ and ®. All trademarks are owned by or licensed to Invacare Corporation or its subsidiaries unless otherwise noted.

Invacare reserves the right to alter product specifications without further notice.

Contents

1 General	7
1.1 Introduction	7
1.2 Symbols in this manual	7
1.3 Intended use	8
1.4 Indications	8
1.5 Type classification	8
1.6 Regulations	8
1.7 Usability	8
1.8 Warranty	9
1.9 Service life	9
1.10 Limitation of liability	9
2 Safety	10
2.1 General safety notes	10
2.2 Safety information on the electrical system	12
2.3 Safety information on electromagnetic interference	14
2.4 Safety information on driving and freewheel mode	15
2.5 Safety information with regard to care and maintenance	18
2.6 Safety information regarding changes and modifications to the mobility device	19
2.7 Safety information on wheelchairs with a lifter	20
2.8 Labels on product	22
3 Components	25
3.1 Main parts of the wheelchair	25
3.2 Remotes	25
3.3 The Lifter	25
4 Accessories	27
4.1 Posture belts	27
4.1.1 Types of posture belts	27
4.1.2 Adjusting the posture belt correctly	27
4.2 Using the cane holder	28
4.3 Using the KLiCKfix adapter	28

4.4 Adjusting or removing the luggage carrier	29
5 Setup	30
5.1 General setup information	30
5.2 Adjustment possibility for remote	31
5.2.1 Adjusting the remote for the length of the user's arm	32
5.2.2 Adjusting remote height	32
5.2.3 Adjusting the height of the remote (only for swing-away remote supports)	32
5.2.4 Adjusting remote width	32
5.2.5 Adjusting remote position	33
5.2.6 Swivelling the remote to the side	33
5.3 Adjustment possibilities for the Firm seat unit	33
5.3.1 Setting the height of the armrests	33
5.3.2 Adjusting the width of the armrests	34
5.4 Adjustment possibilities for the Flex 2 seat unit	34
5.4.1 Adjusting width of the Flex 2 standard armrest	34
5.4.2 Adjusting the position of the armrest in depth	35
5.4.3 Adjust the height of the flip-up armrest	35
5.4.4 Adjusting the angle for armrest with the flip-up armrest	37
5.4.5 Adjusting the width of the flip-up armrest	37
5.4.6 Set the resistance of the flip-up armrest	37
5.4.7 Adjusting the position of the arm pad of the flip-up armrest	38
5.4.8 Setting the Hemi armrest rotation	39
5.5 Adjustment Possibilities for Nucleus Midline Holder	39
5.5.1 Adjusting Depth of Midline Holder	39
5.5.2 Adjusting Height of Nucleus Midline Holder	39
5.5.3 Adjusting Joystick/Display Position on Nucleus Midline Holder	40
5.6 Adjustment Possibilities for Chin Control	41
5.6.1 Adjusting Extremity Control Joystick	41
5.6.2 Adjusting Egg Switch	42
5.7 Adjusting Swing-Away Mechanism	42
5.8 Adjustment options for the Modulite seat unit	43

5.8.1	Adjusting the height of the armrests	43	5.14.3	Swinging the tray away to the side	54
5.8.2	Adjusting the width of the armrests	43	5.15	Vari-F footrest	54
5.8.3	Adjusting the position of the armrest in depth	44	5.15.1	Swivelling the footrest/legrest outward and/or removing	54
5.8.4	Adjusting the seat width	44	5.15.2	Setting the angle	55
5.8.5	Adjusting the seat depth (Modulite seat unit)	45	5.15.3	Setting the end stop of the footrest	55
5.9	Adjusting the seat angle	45	5.15.4	Adjusting the length of the footrest	57
5.9.1	Electrical	45	5.16	Vari-A legrests	57
5.9.2	Manually using spindle	45	5.16.1	Swivelling the footrest/legrest outward and/or removing	57
5.10	Adjusting the backrest	46	5.16.2	Setting the angle	58
5.10.1	Electrical	46	5.16.3	Setting the end stop of the legrest	59
5.10.2	Adjusting the backrest (Firm seat)	46	5.16.4	Adjusting the length of the legrest	61
5.10.3	Adjusting the backrest (Flex 2 seat unit) — manually using the gas pressure spring	47	5.16.5	Adjusting the depth of the calf pad	61
5.10.4	Adjusting the height of the backrest (Modulite seat unit)	47	5.16.6	Adjusting the height of the calf pad	62
5.10.5	Adjusting the width of the backrest (Modulite seat unit)	47	5.16.7	Unlocking and swivelling the calf pad backward when alighting	62
5.10.6	Adjusting the backrest angle (Modulite seat unit)	48	5.16.8	Adjusting the angle—adjustable foot plate	63
5.10.7	Adjusting the tension adjustable backrest upholstery	50	5.16.9	Adjusting the angle— and depth—adjustable foot plate	63
5.11	Adjusting the headrest	50	5.17	Powered elevating legrests (ADE legrests)	64
5.11.1	Adjusting the position of the headrest or neckrest	50	5.17.1	Swivelling the legrest outward and/or removing	64
5.11.2	Adjusting the height of the headrest or neckrest	51	5.17.2	Setting the angle	64
5.11.3	Adjusting the cheek supports	51	5.17.3	Adjusting the length of the legrest	64
5.12	Adjusting the trunk support (Flex 2 seat / Firm seat)	52	5.17.4	Adjusting the depth of the calf pad	65
5.12.1	Adjusting the width	52	5.17.5	Adjusting the height of the calf pad	65
5.12.2	Adjusting the height	52	5.17.6	Unlocking and swivelling the calf pad backward when alighting	65
5.12.3	Adjusting the depth	52	5.17.7	Adjusting the angle—adjustable foot plate	66
5.13	Adjusting the height-adjustable push handle (Flex 2 seat)	53	5.17.8	Adjusting the angle— and depth—adjustable foot plate	66
5.14	Adjusting and removing the tray	53	5.18	Standard 80° footrest	67
5.14.1	Laterally adjusting the tray	53	5.18.1	Swivel the footrests outwards and/or remove them	67
5.14.2	Adjusting the depth of the tray / removing the tray	54	5.18.2	Adjusting the length	67
			5.19	Manually height-adjustable legrest	67

5.19.1	Swivelling the legrest outward and/or removing	67	6.7	Driving up and down gradients	78
5.19.2	Setting the angle	68	6.8	Handling the drive lock-out feature	79
5.19.3	Adjusting the length of the legrest	68	6.9	Use on public roads	79
5.19.4	Adjusting the depth of the calf pad	69	6.10	Pushing the mobility device in freewheel mode	80
5.19.5	Adjusting the height of the calf pad	69	6.10.1	Disengaging motors (conventional motors)	80
5.20	Adjusting the width of the legrests fixed to the side (Flex 2 seat / Modulite seat)	70	7	Controls system	82
5.21	Legrests for the Firm seat	70	7.1	Controls protection system	82
5.21.1	Modifying the front seat depth by adjusting the legrest support brackets	70	7.2	Batteries	82
5.21.2	Adjusting the length of the legrest — Standard / Junior / Mini Legrests (Firm seat)	70	7.2.1	General information on charging	82
5.21.3	Adjusting the angle of the legrest — Angle adjustable legrest	71	7.2.2	General instructions on charging	82
5.21.4	Adjusting the length of the legrest — Angle adjustable legrest	72	7.2.3	How to charge the batteries	83
6	Usage	73	7.2.4	How to disconnect the mobility device after charging	84
6.1	Driving	73	7.2.5	Storage and Maintenance	84
6.2	Before driving for the first time	73	7.2.6	Instructions on using the batteries	84
6.3	Parking and stationary	73	7.2.7	Transporting batteries	85
6.3.1	Activating and deactivating the manual wheel lock	73	7.2.8	General instructions on handling the batteries	85
6.4	Getting in and out of the mobility device	74	7.2.9	How to handle damaged batteries correctly	85
6.4.1	Removing the armrests in order to side transfer (Standard seat / Firm seat / Modulite seat)	74	8	Transport	87
6.4.2	Removing the armrests in order to side transfer (Flex 2 seat)	74	8.1	Transport — General information	87
6.4.3	Information about getting in and out	75	8.2	Transferring the mobility device to a vehicle	87
6.4.4	Swivelling Nucleus Midline Holder to Side	75	8.3	Use of the wheelchair as a seat in a vehicle	88
6.4.5	Swivelling Swing-Away Display Holder to Side	75	8.3.1	How the wheelchair is anchored in a vehicle	89
6.4.6	Swivelling Chin Control to Side	76	8.3.2	How the user is secured within the mobility device	90
6.5	Folding away/releasing the curb climber	76	8.4	Transporting the mobility device without occupant	92
6.6	Taking Obstacles	77	8.4.1	Preparing the wheelchair for transport without occupant	92
6.6.1	Maximum obstacle height	77	8.4.2	Removing the battery boxes	93
6.6.2	Safety information when taking obstacles	77	8.4.3	Removing the seat	94
6.6.3	The correct way to take obstacles	77	8.4.4	Reassembling the wheelchair	94
			8.4.5	Special information about reassembly	95
			9	Maintenance	97
			9.1	Maintenance introduction	97
			9.2	Cleaning the mobility device	97

9.3	Inspection checks	97
9.3.1	Before each use of the mobility device.	97
9.3.2	Weekly	98
9.3.3	Monthly.	99
9.4	Wheels and tires.	99
9.5	Short-term storage	100
9.6	Long-term storage.	100
10	After Use	102
10.1	Reconditioning	102
10.2	Disposal	102
11	Technical Data	103
11.1	Technical specifications	103
12	Service.	112
12.1	Inspections performed.	112

1 General

1.1 Introduction

Thank you for choosing an Invacare product.

This user manual contains important information about the handling of the product. In order to ensure safety when using the product, read the user manual carefully and follow the safety instructions.

Before reading this manual, make sure you have the latest version. You find the latest version as a pdf on the Invacare website (see back page of this manual). If you find that the font size in the print version of the user manual is difficult to read, you can download the pdf from the website. The pdf can then be scaled on screen to a font size that is more comfortable for you.

This mobility device has been constructed for a large circle of users with different requirements.

The decision whether the model is suitable for the user may only be taken by medical specialists with appropriate expertise.

Some maintenance and settings can be performed by the user or his/hers attendants. Certain adjustments do however require technical training and may only be carried out by your Invacare specialist provider. Refer to the Inspection checks chapter in *9 Maintenance, page 97*. Damages and errors caused by nonobservance of the user manual or as a result of incorrect maintenance are excluded from all guarantees.

For more information about the product, for example product safety notices and product recalls, contact your local Invacare representative. For address and website see back page of this manual.

1.2 Symbols in this manual

In this manual, hazard statements are indicated by symbols. The symbols are accompanied by a signal word that indicates the severity of the risk.



WARNING

Indicates a hazardous situation that could result in serious injury or death if it is not avoided.



CAUTION

Indicates a hazardous situation that could result in minor or slight injury if it is not avoided.



IMPORTANT

Indicates a hazardous situation that could result in damage to property if it is not avoided.



Gives useful tips, recommendations and information for efficient, trouble-free use.



This product complies with Directive 93/42/EEC concerning medical devices. The launch date of this product is stated in the CE declaration of conformity.



This symbol identifies a list of various tools, components and items which you will need in order to carry out certain work.

1.3 Intended use

This mobility device was designed for persons whose ability to walk is impaired, but who are still in terms of their eyesight and physically and mentally able to operate an electric mobility device.

1.4 Indications

The use of this power wheelchair is recommended for the following indications:

- The inability or a greatly restricted ability to walk within the scope of the basic requirement to be able to move within one's own four walls.
- The need to leave the dwelling place in order to get some fresh air during a short walk or to reach those places generally to be found at close distance to the dwelling and where everyday business is carried out.

Provision of power wheelchairs for interior and exterior areas is advisable if the use of hand-operated wheelchairs is no longer possible on account of the disability, yet proper operation of an electromotive drive unit is still practicable.

Contraindications

There are no contraindications known.

1.5 Type classification

This vehicle has been classified according to EN 12184 as a **class B mobility product** (for indoor and outdoor areas). It is therefore compact and agile enough for indoor areas, but also able to overcome many obstacles in outdoor areas.

1.6 Regulations

The vehicle was successfully tested according to German and international standards as to its safety. It satisfies the requirements according to RoHS 2011/65/EU, REACH 1907/2006/EC and DIN EN 12184 including EN 1021-2 and ISO 7176–14. It was also tested successfully according to EN 60529 IPX4 as to its resistance to spray water, and is therefore well suited for weather conditions such as typical European weather conditions. When equipped with an appropriate lighting system, the vehicle is suitable for use on public roads.

1.7 Usability

Only use a mobility device when it is in perfect working order. Otherwise, you might put yourself and others at risk.

The following list does not claim to be exhaustive. It is only intended to show some of the situations that could affect the usability of your mobility device.

In certain situations, you should immediately stop using your mobility device. Other situations allow you to use the mobility device to get to your provider.

You should immediately stop using your mobility device if its usability is restricted due to:

- brake failure

You should immediately contact an authorized Invacare provider if the usability of your mobility device is restricted due to:

- the lighting system (if fitted) failing or being defective
- reflectors falling off
- worn thread or insufficient tire pressure

- damage to the armrests (e.g. torn armrest padding)
- damage to the legrest hangers (e.g. missing or torn heel straps)
- damage to the postural belt
- damage to the joystick (joystick cannot be moved into the neutral position)
- cables that are damaged, kinked, pinched or have come loose from the fixation
- the mobility device drifting when braking
- the mobility device pulling to one side when moving
- unusual sounds developing or occurring

Or if you have the feeling that something is wrong with your mobility device.

1.8 Warranty

The terms and conditions of the warranty are part of the general terms and conditions particular to the individual countries in which this product is sold.

1.9 Service life

We estimate a service life of five years for this product, provided it is used in strict accordance with the intended use as set out in this document and all maintenance and service requirements are met. The estimated service life can be exceeded if the product is carefully used and properly maintained, and provided technical and scientific advances do not result in technical limitations. The service life can also be considerably reduced by extreme or incorrect usage. The fact that we estimate a service life for this product does not constitute an additional warranty.

1.10 Limitation of liability

Invacare accepts no liability for damage arising from:

- Non-compliance with the user manual
- Incorrect use
- Natural wear and tear
- Incorrect assembly or set-up by the purchaser or a third party
- Technical modifications
- Unauthorized modifications and/or use of unsuitable spare parts

2 Safety

2.1 General safety notes

**DANGER!****Risk of Death, Serious Injury, or Damage**

Lighted cigarettes dropped onto an upholstered seating system can cause a fire resulting in death, serious injury, or damage. Mobility device occupants are at particular risk of death or serious injury from these fires and resulting fumes because they may not have the ability to move away from the mobility device.

- DO NOT smoke while using this mobility device.

**WARNING!****Risk of injury if mobility device is used in any other way than the purpose described in this manual**

- Only ever use the mobility device in accordance with the instructions in this user manual.
- Pay strict attention to the safety information.

**WARNING!****Risk of injury if the mobility device is driven when ability to operate a vehicle is impaired by medication or alcohol**

- Never drive the mobility device under the influence of medication or alcohol. If necessary, the mobility device must be operated by an attendant who is physically and mentally able.

**WARNING!****Risk of damage or injury if mobility device is accidentally set into motion**

- Switch the mobility device off before you get in, get out or handle unwieldy objects.
- When the drive is disengaged, the brake inside the drive is deactivated. For this reason, pushing the mobility device by an attendant is only recommended on flat surfaces, never on gradients. Never leave your mobility device on a gradient with its motors disengaged. Always re-engage the motors immediately after pushing the mobility device (refer to Pushing the mobility device in freewheel mode).

**WARNING!****Risk of injury if the mobility device is switched off while driving, for example by pressing the On/Off Button or disconnecting a cable, due to it coming to an abrupt, sharp stop**

- If you have to brake in an emergency, simply release the joystick which will bring you to a halt (refer to the remote user manual for more information).

**WARNING!****Risk of injury when transferring mobility device to a vehicle for transport with the occupant seated in it**

- It is always better to transfer the mobility device to a vehicle without the occupant seated in it.
- If the mobility device needs to be loaded up a ramp together with its driver, ensure that the ramp does not exceed the rated slope (refer to *11 Technical Data, page 103*).
- If the mobility device does need to be loaded using a ramp which exceeds the rated slope (refer to *11 Technical Data, page 103*), then you must use a winch. An attendant can safely monitor and assist the loading process.
- As an alternative you can use a platform lift. Ensure that the total weight of the mobility device including the user does not exceed the maximum permissible weight for the platform lift or winch if you are using.

**WARNING!****Risk of falling out of the mobility device**

- Do not slide forward on the seat, do not lean forward between your knees, do not lean backwards out over the top of the backrest, for example to reach an object.
- If a posture belt is installed, it should be correctly adjusted and used each time you use the mobility device.
- When transferring to a different seat, position the mobility device as close as possible to the new seat.

**WARNING!****Risk of Serious Injury or Damage**

- Storing or using the mobility device near open flame or combustible products can result in serious injury or damage.
- Avoid storing or using the mobility device near open flame or combustible products.

**CAUTION!****Risk of injury if maximum permissible load is exceeded**

- Do not exceed the maximum permissible load (refer to *11 Technical Data, page 103*).
- The mobility device is only designed for use by a single occupant whose maximum weight does not exceed the maximum permissible load of the device. Never use the mobility device to transport more than one person.



CAUTION!

Risk of injury due to wrong lifting or dropping of heavy components

- When maintaining, servicing or lifting any part of your mobility device, take into account the weight of the individual components especially the batteries. Be sure at all times to adopt the correct lifting posture and ask for assistance if necessary.



CAUTION!

Risk of injury by moving parts

- Make sure that no injury is incurred by moving parts of the mobility device, like wheels or one of the lifter modules (if fitted), especially when children are around.



CAUTION!

Risk of injury from hot surfaces

- Do not leave the mobility device in direct sunlight for prolonged periods. Metal parts and surfaces such as the seat and armrests can become very hot.



CAUTION!

Risk of fire or breaking down due to electric devices being connected

- Do not connect any electric devices to your mobility device that are not expressly certified by Invacare for this purpose. Have all electrical installations done by your authorized Invacare provider.

2.2 Safety information on the electrical system



WARNING!

Risk of death, serious injury or damage

- Misuse of the mobility device may cause the mobility device to start smoking, sparking, or burning. Death, serious injury, or damage may occur due to fire.
- DO NOT use the mobility device other than its intended purpose.
 - If the mobility device starts smoking, sparking, or burning, discontinue using the mobility device and seek service IMMEDIATELY.



WARNING!

Risk of fire

- Switched on lamps produce heat. If you cover the lamps with fabrics such as clothes, there is a risk that the fabric may catch fire.
- NEVER cover the light system with fabric.

**WARNING!****Risk of death, serious injury or damage when carrying along oxygen systems**

Textiles and other materials that normally would not burn are easily ignited and burn with great intensity in oxygen enriched air.

- Check the oxygen tubing daily, from the cylinder to the delivery site, for leaks and hold away from electrical sparks and any source of ignition.

**WARNING!****Risk of death, serious injury, or damage**

Corroded electrical components due to water or liquid exposure can result in death, serious injury, or damage.

- Minimize exposure of electrical components to water and/or liquids.
- Electrical components damaged by corrosion **MUST** be replaced immediately.
- Mobility devices that are frequently exposed to water/liquids may require replacement of electrical components more frequently.

**WARNING!****Risk of injury or damage due to electrical shorts**

Connector pins on cables connected to the power module can still be live even when the system is off.

- Cables with live pins should be connected, restrained or covered (with non-conductive materials) so that they are not exposed to human contact or materials that could cause electrical shorts.
- When cables with live pins have to be disconnected, for example, when removing the bus cable from the remote for safety reasons, make sure to restrain or cover the pins (with non-conductive materials).



WARNING!

Risk of death or serious injury

Failure to observe these warnings can cause an electrical short resulting in death, serious injury, or damage to the electrical system.

- The POSITIVE (+) RED battery cable MUST connect to the POSITIVE (+) battery terminal(s)/post(s). The NEGATIVE (-) BLACK battery cable MUST connect to the NEGATIVE (-) battery terminal(s)/post(s).
- NEVER allow any of your tools and/or battery cable(s) to contact BOTH battery post(s) at the same time. An electrical short may occur and serious injury or damage may occur.
- Install protective caps on positive and negative battery terminals.
- Replace cable(s) immediately if cable(s) insulation becomes damaged.
- DO NOT remove fuse or mounting hardware from POSITIVE (+) red battery cable mounting screw.



WARNING!

Risk of death or serious injury

Electric shock can cause death or serious injury

- To avoid electric shock, inspect plug and cord for cuts and/or frayed wires. Replace cut cords or frayed wires immediately.



Risk of damage to the mobility device

A failure in the electric system can lead to unusual behavior such as continuous light, no light, or noises from the magnetic brakes.

- If a failure exists, switch off the remote and switch it on again.
- If a failure still exists, then disconnect or remove the power source. Depending on the mobility device model, you can either remove the battery packs or disconnect the batteries from the power module. If in doubt which cable to disconnect, contact your provider.
- In any case, contact your provider.

2.3 Safety information on electromagnetic interference

This electric vehicle was successfully tested in accordance with International standards as to its compliance with Electromagnetic Interference (EMI) regulations. However, electromagnetic fields, such as those generated by radio and television transmitters, and cellular phones can influence the functions of electric vehicles. Also, the electronics used in our vehicles can generate a low level of electromagnetic interference, which however will remain within the tolerance permitted by law. For these reasons we ask you to please observe the following precautions:

**WARNING!****Risk of malfunction due to electromagnetic interference**

- Do not switch on or operate portable transceivers or communication devices (such as radio transceivers or cellular phones) when the vehicle is switched on.
- Avoid getting near strong radio and television transmitters.
- In case the vehicle should be set in motion unintentionally or the brakes are released, switch it off immediately.
- Adding electrical accessories and other components or modifying the vehicle in any way can make it susceptible to electromagnetic interference. Keep in mind that there is no sure way to determine the effect such modifications will have on the overall immunity of the electronic system.
- Report all occurrences of unintentional movement of the vehicle, or release of the electric brakes to the manufacturer.

2.4 Safety information on driving and freewheel mode

**DANGER!****Risk of death, serious injury, or damage**

- Malfunctioning joystick could cause unintended/erratic movement resulting in death, serious injury, or damage
- If unintended/erratic movement occurs, stop using the wheelchair immediately and contact a qualified technician.



WARNING!

Risk of injury if the mobility device tips over

- Inclines and declines can only be travelled up to the maximum safe slope (refer to 11 *Technical Data, page 103*).
- Always return the backrest of your seat or the seat tilt to an upright position before ascending slopes. We recommend that you position the seat backrest and the seat tilt (if fitted) slightly to the rear before descending slopes.
- Only ever drive downhill at a maximum of 2/3 of the top speed. Avoid abrupt braking or accelerating on gradients.
- If at all possible, avoid driving on wet, slippery, icy, or oily surfaces (such as snow, gravel, ice etc.) where there is a risk of you losing control over the vehicle, especially on a gradient. This may include certain painted or otherwise treated wood surfaces. If driving on such a surface is inevitable, then always drive slowly and with the utmost caution.
- Never attempt to overcome an obstacle when on an uphill or downhill gradient.
- Never attempt to drive up or down a flight of steps with your mobility device.
- When overcoming obstacles, always observe the maximum obstacle height (refer to 11 *Technical Data, page 103* and information about overcoming obstacles in 6.6 *Taking Obstacles, page 77*).
- Avoid shifting your center of gravity as well as abrupt joystick movements and changes of direction when the mobility device is in motion.



WARNING!

Risk of injury if the mobility device tips over (continued)

- Never use the mobility device to transport more than one person.
- Do not exceed the overall maximum permissible load or the maximum load per axle (refer to 11 *Technical Data, page 103*).
- Note that the mobility device will brake or accelerate if you change the driving mode whilst the mobility device is in motion.



WARNING!

Risk of serious injury or damage

- Improper positioning while leaning or bending could cause the wheelchair to tip forward resulting in serious injury or damage
- To assure stability and proper operation of your mobility device, you must at all times maintain proper balance. Your power wheelchair has been designed to remain upright and stable during normal daily activities as long as you DO NOT move beyond the center of gravity.
 - DO NOT lean forward out of the mobility device any further than the length of the armrests.
 - DO NOT attempt to reach objects if you have to move forward in the seat or pick them up from the floor by reaching down between your knees.

**WARNING!**

Risk of breaking down in adverse weather conditions, i.e. extreme cold, in an isolated area

- If you are a user with severely limited mobility, we advise that in the case of adverse weather conditions DO NOT attempt a journey without an accompanying attendant.

**WARNING!**

Risk of injury if your foot slides off the footrest and gets caught underneath the mobility device when it is in motion

- Make sure each time before you drive the mobility device that your feet are squarely and securely in place on the footplates, and that both legrests are properly locked into place.

**WARNING!**

Risk of injury if you collide with an obstacle when driving through narrow passages such as doorways and entrances

- Drive through narrow passages in the lowest driving mode and with due caution.

**WARNING!**

Risk of injury

- If your mobility device has been fitted with elevating legrests, there is a risk of personal injury and damage to the mobility device if you drive the mobility device with the legrests raised.
- To avoid unwanted displacement of the mobility device center of gravity to the front (especially when travelling downhill) and in order to avoid damage to the mobility device, elevating legrests must always be lowered during normal travelling.

**WARNING!**

Tipping hazard if antitippers are removed, damaged or changed to a position different to the factory settings

- Antitippers should only ever be removed for dismantling the mobility device for transport in a vehicle or for storage.
- The antitippers must always be fitted if the mobility device is being used.



WARNING!

Risk of tipping

Antitippers (stabilizers) are only effective on firm ground. They sink in on soft ground such as grass, snow or mud if the mobility device rests itself on them. They lose their effect and the mobility device can tip over.

- Only drive with extreme care on soft ground, especially during uphill and downhill journeys. In the process pay increased attention to the tip stability of the mobility device.

2.5 Safety information with regard to care and maintenance



WARNING!

Risk of death, serious injury, or damage

Incorrect repair and/or servicing of this mobility device performed by users/caregivers or unqualified technicians can result in death, serious injury, or damage.

- DO NOT attempt to carry out maintenance work that is not described in this user manual. Such repair and/or service MUST be performed by a qualified technician. Contact a provider or Invacare technician.



CAUTION!

Risk of accident and loss of warranty if maintenance is insufficient

- For reasons of safety and in order to avoid accidents which result from unnoticed wear, it is important that this mobility device undergoes an inspection once every year under normal operating conditions (see inspection plan contained in service instructions).
- Under difficult operating conditions such as daily travel on steep slopes, or in the case of use in medical care cases with frequently changing mobility device users, it would be expedient to carry out intermediate checks on the brakes, accessories and running gear.
- If the mobility device is to be operated on public roads, the vehicle driver is responsible for ensuring that it is in an operationally reliable condition. Inadequate or neglected care and maintenance of the mobility device will result in a limitation of the manufacturer's liability.

2.6 Safety information regarding changes and modifications to the mobility device



WARNING!

Risk of serious injury or damage

Use of incorrect or improper replacement (service) parts may cause injury or damage

- Replacement parts **MUST** match original Invacare parts.
- Always provide the wheelchair serial number to assist in ordering the correct replacement parts.



CAUTION!

Risk of injuries and damage to mobility device due to unapproved components and accessory parts

Seating systems, additions and accessory parts which have not been approved by Invacare for use with this mobility device can affect the tipping stability and increase tipping hazards.

- Only ever use seating systems, additions and accessory parts which have been approved by Invacare for this mobility device.

Seating systems which are not approved by Invacare for use with this mobility device do not, under certain circumstances, comply with the valid standards and could increase the flammability and the risk of skin irritation.

- Only use seating systems that have been approved by Invacare for this mobility device.

Electrical and electronic components which have not been approved by Invacare for use with this mobility device can cause fire hazards and lead to electromagnetic damage.

- Only ever use electrical and electronic components which have been approved by Invacare for this mobility device.

Batteries which have not been approved by Invacare for use with this mobility device can cause chemical burns.

- Only ever use batteries which have been approved by Invacare for this mobility device.



CAUTION!

Risk of injuries, and damage to the mobility device, if unapproved backrests are used

A retrofitted backrest which is not approved by Invacare for use with this mobility device may overload the backrest tube and thus increase the risk of injuries and of damage to the mobility device.

- Please contact your Invacare specialist provider who will perform risk analyses, calculations, stability checks etc. to ensure that the backrest can be used safely.



CE marking of the mobility device

- The conformity assessment/CE marking was carried out in accordance with Directive 93/42 EEC and only applies to the complete product.
- The CE marking is invalidated if components or accessories are replaced or added that have not been approved for this product by Invacare.
- In this case, the company that adds or replaces the components or accessories is responsible for the conformity assessment/CE marking or for registering the mobility device as a special design and for the relevant documentation.



Important information about maintenance work tools

- Some maintenance work which is described in this manual and can be carried out by the user without problems require the correct tools for proper work. If you do not have the correct tool available we do not recommend that you try to carry out the relevant work. In this case, we urgently recommend that you contact an authorized specialist workshop.

2.7 Safety information on wheelchairs with a lifter



WARNING!

Risk of injury by moving parts

- Never let objects get caught in the space underneath a raised lifter.
- Make sure that neither you nor anyone else is injured by placing hands, feet or other body extremities under the raised seat.
- Should you not be able to view under the seat, for example, due to limited manoeuvrability, turn the wheelchair once on its own axle before you lower the seat. This will allow you to make sure that nobody is located in the danger zone.

**CAUTION!****Risk of injury if the wheelchair tips over**

- Never exceed the maximum permissible load (see chapter *11 Technical Data, page 103*).
- Avoid dangerous driving situations when the lifter is in a raised position, such as trying to overcome obstacles like curbs or driving up or down steep gradients.
- Never lean out of the seat when the lifter is raised.
- Inspect the lifter module at least once a month to make sure the automatic speed reduction function, which reduces the speed of the wheelchair when the lifter is raised, is working properly (see chapter *The Lifter*). Notify your authorized provider immediately if it is not working properly.

**CAUTION!****Risk of malfunction of the lifter module**

- Inspect the lifter module at regular intervals to make sure there are no foreign objects or visible damage, and to make sure the electric plugs are firmly inserted into their sockets.

**CAUTION!****Damage to wheelchair caused by one-sided loading on lifter pillar**

- One-sided loading occurs if the seat is raised and/or tilted. Always return your seat backrest to the upright position and the seat tilting to the horizontal position before ascending slopes. Never subject the lifter pillar to continuous single-sided loading. The raising and tilting function of the seat only provides additional rest positions.

**Important information regarding speed reduction with raised lifter**





- If the lifter has been raised above a certain point, the drive electronics considerably reduces the speed of the wheelchair. If speed reduction has been activated, drive mode can only be used to carry out minor movements of the wheelchair and not for regular driving. To drive normally, lower the lifter until the speed reduction has been deactivated again. See chapter *The Lifter* for details.

2.8 Labels on product









<p>A</p>		<p>If the mobility device is fitted with a tray, it is imperative that it is removed and safely stowed when transporting the mobility device in a vehicle.</p>
<p>B</p>	<p>Identification of the tie-down points at the front and back:</p>	





	<p>ISO 7176-19</p>	<p>If the symbol appears on a bright yellow sticker, the tie-down point is suitable for fixation of the mobility device in a vehicle for use as a vehicle seat.</p>
<p>C</p>	<p>ISO 7176-19</p>	<p>Warning that the mobility device may not be used as a vehicle seat.</p> <p>This mobility device does not satisfy the requirements of ISO 7176-19.</p>
		<p>Identification label sticker on the chassis at the front right.</p> <p>For details see below.</p>
<p>D</p>		<p>Warning regarding the use of the lifter</p> <p>For details see below</p>

<p>Ⓔ</p>		<p>Identification of the position of the engaging turn knob for driving and push operation (only the right side is visible in the picture).</p> <p>For details see below.</p>
<p>Ⓕ</p>		<p>Indication of the maximum width to which the armrest can be set</p>
<p>Ⓖ</p>		<p>Maximum speed label on the remote.</p> <p>The maximum speed is reduced to 3 km/h.</p>
<p>Ⓗ</p>		<p>Indication of pinch points that could occur on the mobility device</p>

Explanation of symbols on labels

	<p>Date of manufacture</p>
	<p>This product complies with Directive 93/42/EEC concerning medical devices. The launch date of this product is stated in the CE declaration of conformity.</p>

	<p>This product has been supplied from an environmentally aware manufacturer. This product may contain substances that could be harmful to the environment if disposed of in places (landfills) that are not appropriate according to legislation.</p> <ul style="list-style-type: none"> • The 'crossed out wheellie bin' symbol is placed on this product to encourage you to recycle wherever possible. • Be environmentally responsible and recycle this product through your recycling facility at its end of life.
	<p>Do not lean out when the lifter is raised!</p>
	<p>Do not drive up or down slopes when the lifter is raised!</p>
	<p>Do not allow any body parts to get under a raised seat!</p>
	<p>Never drive with two people!</p>

	<p>Never drive over uneven surfaces when the lifter is raised!</p>
	<p>Read the user manual. This symbol appears on different labels and positions.</p>
	<p>This symbol indicates the “Drive” position of the engaging turn knob. In this position the motor is engaged and the motor brakes are operational. You can drive the mobility device.</p> <ul style="list-style-type: none"> • Note that for driving purposes both motors must always be engaged.
	<p>This symbol indicates the “Push” position of the engaging turn knob. In this position the motor is disengaged and the motor brakes are not operational. The mobility device can be pushed by an attendant and the wheels turn freely.</p> <ul style="list-style-type: none"> • Note that the remote must be switched off. • Also note the information provided in section 6.10 <i>Pushing the mobility device in freewheel mode</i>, page 80.

3 Components

3.1 Main parts of the wheelchair



- Ⓐ Push handle
- Ⓑ Armrest
- Ⓒ Drive wheel
- Ⓓ Turn knob for disengaging a motor (only the right side is visible in the picture)

- Ⓔ Remote
- Ⓕ Legrests

3.2 Remotes

Your mobility device may be fitted with one of several different remotes. For information on the different functions and how to operate a particular remote, refer to its corresponding user manual (enclosed).

3.3 The Lifter

The electric lifter is operated from the remote. Refer to the remote manual for more information.



Information regarding operation of the lifter at temperatures of less than 0 °C

- Invacare mobility aids are fitted with safety mechanisms that prevent capacity overload of the electronic components. At operating temperatures below freezing point this can, in particular, lead to the lifter actuator being shut down after approx. 1 second operating time.
- The lifter can be raised or lowered gradually by repeatedly operating the joystick. In many cases this generates sufficient heat for the actuator to operate as normal.



Speed limiter

The speed limit reacts in different ways, depending on the mobility device's configuration.

- Either the lifter is fitted with sensors which reduce the mobility device's speed as soon as the lifter is raised above a certain point.
- Or if the speed limit is activated, a reduced drive level (forced profile) is set automatically. Refer to the remote manual for more information.
- The speed reduction takes place to guarantee the tipping stability of the mobility device and to avoid personal risk and damage to the mobility device.
- To reapply normal speed, lower the lifter down until the forced profile or the speed reduction switches off.
- If the mobility device is fitted with a chin control, it reacts different to forced profile. Refer to the manual of the chin control for more information.



Limit switch

- If the lifter is raised above a certain point you can adjust the seat and backrest angles only at a combined total of max. 15° to ensure a safe driving behaviour. The set-up allows full tilt and backrest adjustment when the lifter is down. In case the tilt and backrest angle exceed 15° (e.g. 10° tilt and 10° backrest recliner) the lifter function is disabled.



CAUTION!

Risk of tipping, if the speed limiter sensors fail when the lifter is raised

- If you find that the speed reduction function is not working when the lifter is raised, do not drive with the lifter raised and immediately contact an authorized Invacare provider.

4 Accessories

4.1 Posture belts

A posture belt is an option which can either be fixed to the mobility device ex-works or can be retrofitted by your specialist provider. If your mobility device is fitted with a posture belt, your specialist provider will have informed you about fitting and usage.

The posture belt is used to help the mobility device user keep an optimum seating position. Correct use of the belt assists the user in sitting securely, comfortably and well-positioned in the mobility device, especially for such users who do not have such a good sense of balance while sitting.



We recommend using the posture belt whenever the mobility device is used.

4.1.1 Types of posture belts

Your mobility device can be fitted with the following posture belt types ex-works. If your mobility device has been fitted with a different belt to those listed below, please ensure that you have received the manufacturer's documentation with regard to correct fitting and use.

Belt with metal buckle, adjustable one side



Belt can only be adjusted on one side which can result in the buckle not sitting centrally.

Belt with metal buckle, adjustable both sides



Belt can be adjusted on both sides. This means that the buckle can be centrally positioned.

4.1.2 Adjusting the posture belt correctly



The belt should be tight enough to ensure that you are sitting comfortably and that your body is in the correct sitting position.

1. Ensure that you are sitting correctly, which means that you are sitting right at the back of the seat, your pelvis is positioned erect and as symmetrically as possible, not to the front, to the side or at one edge of the seat.
2. Position the posture belt so that your hipbones can be easily felt above the belt.
3. Adjust the belt length using one of the adjustment aids described above. The belt should be adjusted so that you can fit a flat hand between the belt and your body.

- The buckle should be positioned as centrally as possible. In doing so, carry out adjustments on both sides as much as possible.
- Check your belt every week to ensure that it is still in good working condition, to ensure it has no damage or wear, and that it is fixed properly to the mobility device. If the belt is only fastened with a bolted connection, ensure that the connection has not loosened or come undone. You can find more information about maintenance work on belts in the service manual, which is available from Invacare.

4.2 Using the cane holder

If your mobility device is fitted with a cane holder, it can be used for the safe transport of a walking cane, underarm or forearm crutches. The cane holder consists of a plastic container (bottom) and a hook-and-loop fastener (top).



CAUTION! Risk of injury

A walking cane or crutches that are not secured during transport (on the user's lap, for example) can cause injury to the user or other persons.

- During transport, walking canes or crutches should always be secured using a cane holder.

- Open the upper hook-and-loop fastener.
- Place the lower end of the walking cane or the crutches in the container at the bottom.
- The walking cane or the crutches can be secured at the upper end using the hook-and-loop fastener.

4.3 Using the KLICKfix adapter

Your mobility device can be fitted with the mini-adapter from the Rixen + Kaul KLICKfix system. To this you can attach various accessories such as the cellphone case supplied by Invacare, which you can use to transport your cellphone, sports glasses etc.



Risk posed by unsecured accessories

Accessories can fall off and get lost if they are not properly secured.

- Check that the accessory is correctly locked in and seated securely every time you use the mobility device.



Risk of breakage due to excessive load

The KLICKfix adapter can break if too great a load is applied.

- The maximum permitted load on the KLICKfix adapter is 1 kg.

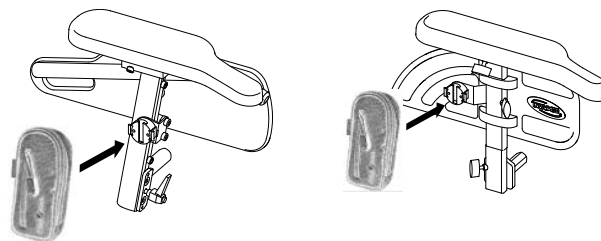

Securing the accessory:

1. Push the accessory into the KLICKfix adapter.
The accessory locks in securely.

Removing the accessory:

1. Press the red button and remove the accessory.

The adapter can turn in 90° steps, allowing you to attach an accessory from any of four different directions. Please refer to the installation instructions which are available from your Invacare provider or directly from Invacare.

More information on the KLICKfix system is available at <http://www.klickfix.com>.

4.4 Adjusting or removing the luggage carrier

- ! **Risk of damage as a result of collisions**
Parts of the mobility device may be damaged if the luggage carrier collides with the seat during seat angle or backrest adjustment.
 - Ensure that the luggage carrier is out of the range of both seat angle and backrest adjustment.

- ! **Risk of breakage due to excessive load**
The luggage carrier can break if too great a load is applied.
 - The maximum permitted load on the luggage carrier is 10 kg.

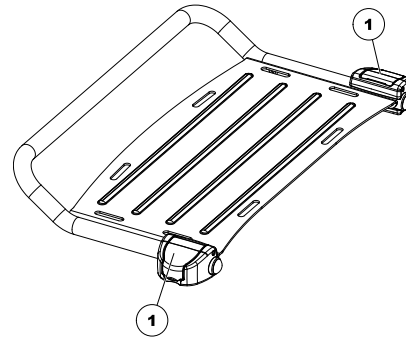

1. Open the clamp levers (1) of the luggage carrier bracket.
2. Slide the luggage carrier forward or backward or remove it.
3. Close the clamp levers of the luggage carrier bracket.

5 Setup

5.1 General setup information

**WARNING!****Risk of death, serious injury, or damage**

Continued use of the mobility device that is not set to the correct specifications may cause erratic behavior of the mobility device resulting in death, serious injury, or damage.

- Performance adjustments should only be made by professionals of the healthcare field or persons fully conversant with this process and the driver's capabilities.
- After the mobility device has been set-up/adjusted, check to make sure that the mobility device performs to the specifications entered during the set-up procedure. If the mobility device does not perform to specifications, IMMEDIATELY turn the mobility device Off and re-enter set-up specifications. Contact Invacare, if mobility device still does not perform to correct specifications.

**WARNING!****Risk of death, serious injury, or damage**

Attaching hardware that is loosely secured or missing could cause instability resulting in death, serious personal injury, or property damage.

- After ANY adjustments, repair or service and before use, make sure that all attaching hardware is present and tightened securely.

**WARNING!****Risk of injury or damage**

Incorrect set up of this mobility device performed by users/caregivers or unqualified technicians can result in injury or damage.

- DO NOT attempt to set up this mobility device. Initial set up of this mobility device MUST be performed by a qualified technician.
- Adjustment by the user is only recommended after they have been given appropriate guidance by the healthcare professional.
- DO NOT attempt to carry out the work if you do not have the listed tools available.

**CAUTION!****Damage to mobility device and accident hazard**

It is possible that collisions can occur between mobility device components due to various combinations of adjustment options and their individual settings

- The mobility device is fitted with an individual, multiply adjustable seating system including adjustable legrests, armrests, a headrest or other options. These adjustment options are described in the following chapters. They are used to adapt the seat to the physical requirements and the condition of the user. When adapting the seating system and the seat functions to the user, ensure that no mobility device components collide.

 Initial setup should always be done by a healthcare professional. Adjustment by the user is only recommended after they have been given appropriate guidance by the healthcare professional.

 Note that there may be sections in this user manual, which are not relevant to your product, since this manual applies to all existing modules (on the date of printing).

Electrical adjustment options

 Refer to the user manual for your remote for more information on operating electrical adjustment options.

5.2 Adjustment possibility for remote

The following information is valid for all seating systems.



CAUTION!

Risk of the remote being pushed backwards during an accidental collision with an obstacle, such as a doorframe or table, and the joystick being jammed against the armpad if the position of the remote is adjusted and all screws are not completely tightened

This will cause the mobility device to drive forward uncontrollably and potentially injure the mobility device user and any person standing in the way.

- When adjusting the position of the remote, always make sure to tighten all screws securely.
- If this should accidentally happen, immediately switch the mobility device electronics OFF at the remote.



CAUTION!

Risk of injury

When leaning on the remote, for example, when transferring into or out of the wheelchair, the remote holder may break and the user may fall out of the chair.

- Never lean on the remote as a support for, for example, transfer.

5.2.1 Adjusting the remote for the length of the user's arm

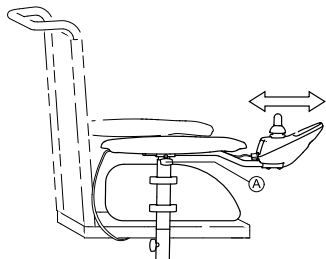

1. Loosen wing bolt (A).
2. Shift the remote forwards or backwards to the desired distance.
3. Retighten the bolt.

5.2.2 Adjusting remote height

-
-  • 3 mm Allen key
-

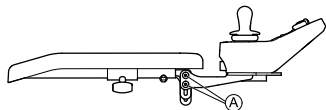

1. Loosen Allen screws (A).
2. Adjust remote to desired height.
3. Re-tighten Allen screws.

5.2.3 Adjusting the height of the remote (only for swing-away remote supports)

-
-  • 6 mm Allen key
-

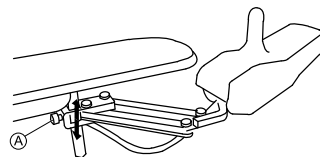

1. Loosen Allen screw (A).
2. Adjust remote to desired height.
3. Re-tighten Allen screw.

5.2.4 Adjusting remote width

The remote can be adjusted 0.8 in (20 mm) widthwise.

-
-  • 3 mm Allen key
-

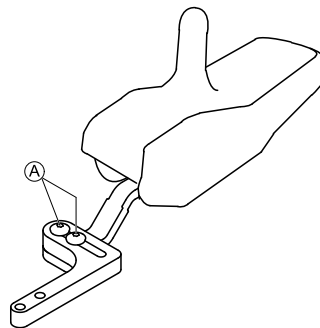

Fig. 5-1

1. Loosen Allen screws (A).
2. Adjust remote to desired width.
3. Re-tighten Allen screws.

5.2.5 Adjusting remote position



- 3 mm Allen key

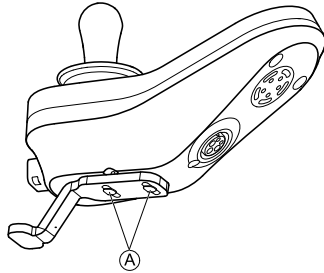

1. Loosen Allen screws (A).
2. Adjust remote to desired position.
3. Re-tighten Allen screws.

5.2.6 Swivelling the remote to the side

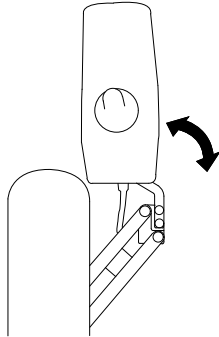

If your mobility device is fitted with a swing-away remote holder, then the remote can be moved away to the side, for example, to drive up close to a table.

5.3 Adjustment possibilities for the Firm seat unit

5.3.1 Setting the height of the armrests



Tools:

- 1 x Phillips screwdriver



The armrest on the Firm seat is fitted with a screw (1) which is used as a stop. The armrest height is adjusted using this stop.

1.

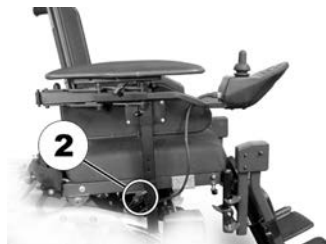

Release wing screw (2).

2. Remove the armrest from the mounting.

3.



Remove the screw (1) using the Phillips screwdriver.

4. Set the new armrest height by selecting a higher or lower screw hole.

5. Retighten the screw.

6. Introduce the armrest into the mounting again. Tighten the wing screw.

7. Repeat the process for the other side if necessary.

34

5.3.2 Adjusting the width of the armrests



WARNING!

Serious injury hazard if one of the armrests falls out of its bracket because they have been adjusted to a width which exceeds the permissible value

– The armrest width adjustment for the Firm seat unit is limited on both sides by a spring-loaded pin. This limiting pin may only be pressed in to remove the armrest completely (e.g. for getting in and out) and never to extend the width adjustment.

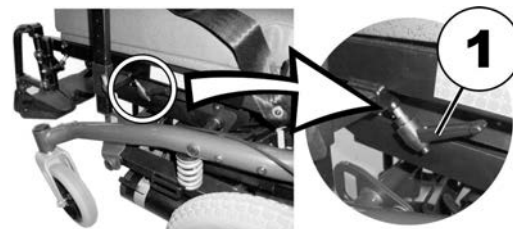

1. Loosen clamping lever (1).

2. Adjust armrest to required position.

3. Retighten the clamping lever.

4. Repeat this procedure for the second armrest.

5.4 Adjustment possibilities for the Flex 2 seat unit

5.4.1 Adjusting width of the Flex 2 standard armrest



- 8 mm Allen key

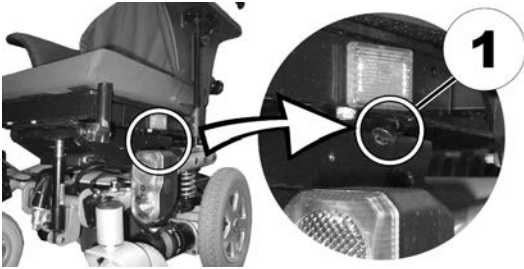

1. Loosen screw (1).
2. Adjust armrest to required position.
3. Retighten the screw.
4. Repeat this procedure for the second armrest.

5.4.2 Adjusting the position of the armrest in depth



WARNING!

Serious risk of injury if an armrest falls out of its bracket because it was pulled too far forward.

- The armrest may be pulled forward out of the bracket as far as the point where the end of the inserted tube is flush with the rear of the bracket, but no further.



- 3 mm Allen key

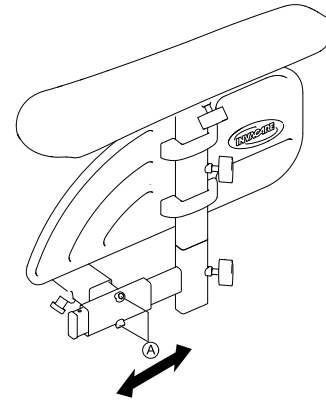

1. Loosen screws Ⓐ and move armrest in depth.
2. Tighten screws securely.

5.4.3 Adjust the height of the flip-up armrest

The height of the flip-up armrests can be set using two methods:

- Normally using the profile on the chair back. See **Method 1**.
- If this is not possible because the lateral supports have to be mounted at the same level for example, then the height can be set using the angle of the armrests. See **Method 2**.

Method 1



- Allen key 5 mm

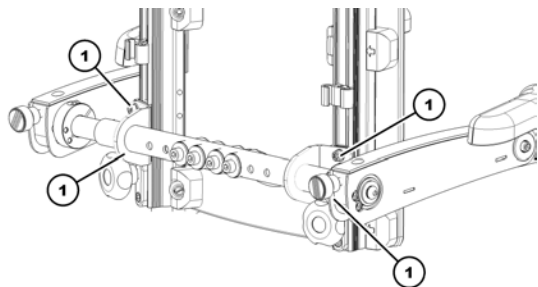

1. Release the interior bolts (1) with the Allen key.
2. Set the height for the armrest.
3. Retighten the bolts.

Method 2

1.



Fig. 5-2

Release the knob to adjust the armrest angle (1).

2.



Fig. 5-3

Set the angle for the armrest.

3. Retighten the knob.

After adjusting the armrest height, the angle of the armrest needs to be adjusted. See 5.4.4 *Adjusting the angle for armrest with the flip-up armrest*, page 37.

5.4.4 Adjusting the angle for armrest with the flip-up armrest



- 5 mm Allen key



1. Release the bolts to adjust the armrest angle (1) with the Allen key.
- 2.



Set the angle for the armrest.

3. Re-tighten the bolts. Make sure that the Nordlock washers used are re-inserted.

5.4.5 Adjusting the width of the flip-up armrest



- 6 mm Allen key
- 13 mm Allen key

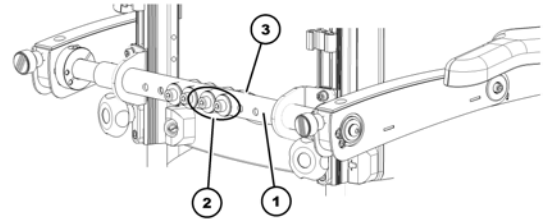

1. Remove the rear cover held by the velcro strips.
2. Release the bolts (2) in the torque support (1) using the Allen key. Maintain counter pressure on the nuts (3) with the Allen key.
3. Set the width of the armrest. The possible positions of the armrests are set using the bores in the torque support.
4. Retighten the bolts.
5. Repeat the process on the other armrest.

5.4.6 Set the resistance of the flip-up armrest

The movement of the flip-up armrests can be set to have greater or less resistance.



- 5 mm Allen key

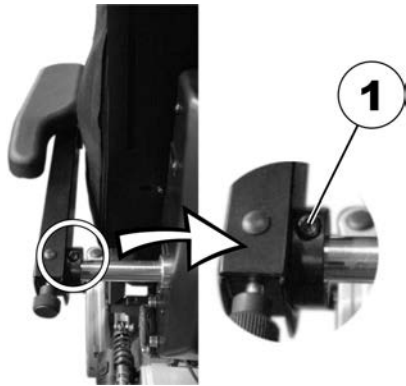

1. To make the armrest easier to move, release the bolt of the adjusting wrench (1) with the Allen key.
2. To make the armrest more difficult to move, tighten the bolt of the adjusting wrench (1) with the Allen key.

5.4.7 Adjusting the position of the arm pad of the flip-up armrest



- 5 mm Allen key



1. Put the armrest in the vertical position.
2. Release the interior bolts (1) with the Allen key.

3.



Position the armrest horizontally.

4. Re-tighten the bolts.

Make sure that the Nordlock washers used are re-inserted.

5.4.8 Setting the Hemi armrest rotation



1. Swivel the armrest inwards or outwards.

5.5 Adjustment Possibilities for Nucleus Midline Holder

5.5.1 Adjusting Depth of Midline Holder

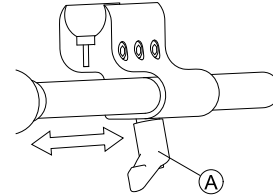

1. Loosen lever Ⓐ.
2. Shift midline holder to desired position.
3. Tighten lever.

5.5.2 Adjusting Height of Nucleus Midline Holder

You can adjust the height of the nucleus midline holder in two ways:

- Adjust it together with the armrest height. Refer to corresponding armrest chapters.
- Adjust the height of the nucleus midline holder only. Refer to section below.



- 3/16" (4.8 mm) Allen key

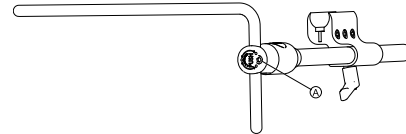

1. Loosen screw (A).
2. Adjust nucleus to desired height.
3. Tighten screw.

5.5.3 Adjusting Joystick/Display Position on Nucleus Midline Holder

DLX-REM500

-  • 3/16" (4.8 mm) Allen key

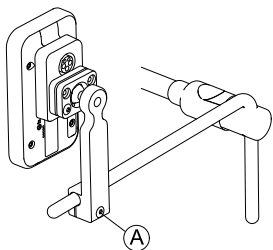

1. Loosen screw (A).
2. Position display on nucleus.
3. Tighten screw.

DLX-CR400 and DLX-CR400LF

-  • 5/32" (4 mm) Allen key

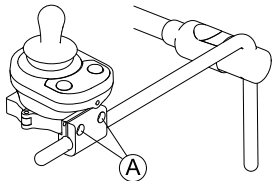

1. Loosen screws (A).
2. Position joystick on nucleus.
3. Tighten screws.

-  • 1/8 " (3 mm) Allen key

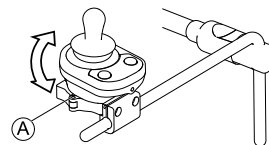

1. Loosen screw (A).
2. Open clamp and position joystick on nucleus.
3. Tighten screw.

ASL Components on Nucleus Tray

-  • 3/16" (4.8 mm) Allen key

The following graphic serves as an example.

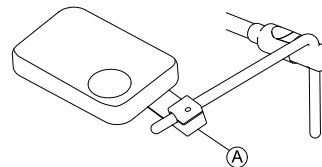

1. Loosen screw (A).
2. Position joystick on nucleus.
3. Tighten screw.

ASL Components on Nucleus Only



- 5/32" (4 mm) Allen key
-

The following graphic serves as an example.

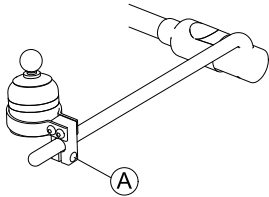

1. Loosen screw Ⓐ.
2. Position joystick on nucleus.
3. Tighten screw.

5.6 Adjustment Possibilities for Chin Control

5.6.1 Adjusting Extremity Control Joystick

Adjusting Position on Holder



- 5/32" (4 mm) Allen key
-

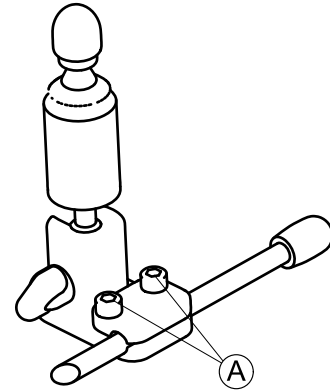

1. Loosen screws Ⓐ.
2. Position joystick on holder.
3. Tighten screws.

Adjusting Joystick Orientation

The joystick can be turned through 360 degrees. A slot on the side allows you to angle the joystick at 90 degrees.

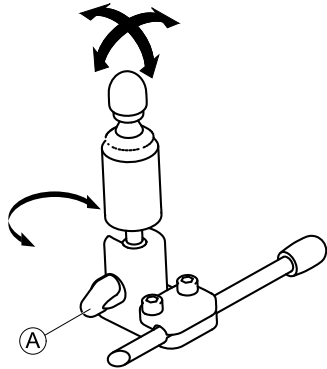

1. Loosen hand screw (A).
2. Turn underpart of joystick to position slot.
3. Adjust joystick orientation. If desired, lock joystick in 90 degree angle in slot.
4. Tighten hand screw.

Adjusting Depth and Height

Refer to 5.7 *Adjusting Swing-Away Mechanism*, page 42.

5.6.2 Adjusting Egg Switch

Adjusting Switch Orientation

The egg switch can be turned through 360 degrees.



- 7/16" (11.2 mm) wrench

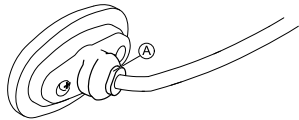

1. Loosen nut (A).
2. Adjust egg switch orientation.
3. Tighten nut.

Adjusting Depth and Height

Refer to 5.7 *Adjusting Swing-Away Mechanism*, page 42.

5.7 Adjusting Swing-Away Mechanism

The swing-away mechanism can be used for different options such as:

- PROTON wings of head array
- Extremity control joystick for chin control
- Egg switch



- 5/32" (4 mm) Allen key

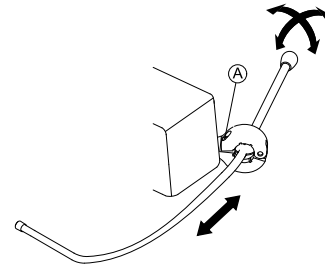

Adjusting Depth

1. Loosen screw (A).
2. Adjust rod to desired depth.
3. Tighten screw.

Adjusting Position

The swing-away mechanism can be turned through 360 degrees.

1. Loosen screw (A).
2. Adjust to desired position.
3. Tighten screw.

5.8 Adjustment options for the Modulite seat unit

5.8.1 Adjusting the height of the armrests

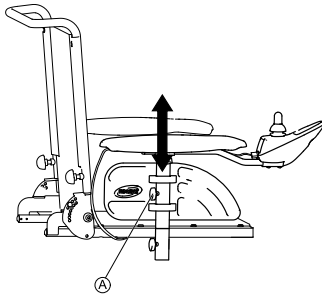

1. Loosen wing screw (A).
2. Adjust armrest to desired height.
3. Re-tighten wing screw.

5.8.2 Adjusting the width of the armrests



WARNING!

Serious injury hazard if one of the armrests falls out of its bracket because they have been adjusted to a width which exceeds the permissible value

- The width adjustment is fitted with red markings (A) and the word "STOP". The armrests must never be pulled out further than the point at which the word "STOP" is completely legible.
- Always tighten the fixing screws properly once adjustments have been completed.

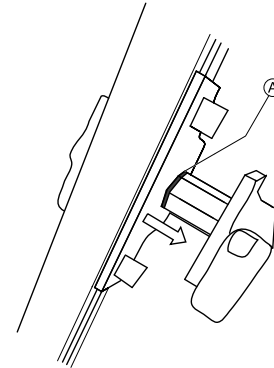

Depending on the side, the screw is accessible from the front or the rear.



- 8 mm Allen key

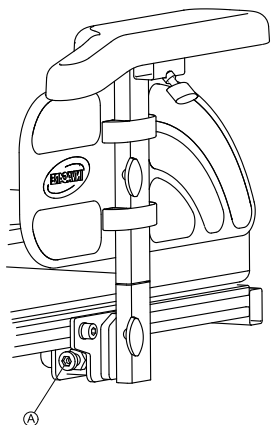

1. Loosen screw Ⓐ.
2. Adjust armrest to required position.
3. Retighten the screw.
4. Repeat this procedure for the second armrest.

5.8.3 Adjusting the position of the armrest in depth



- 6 mm Allen key

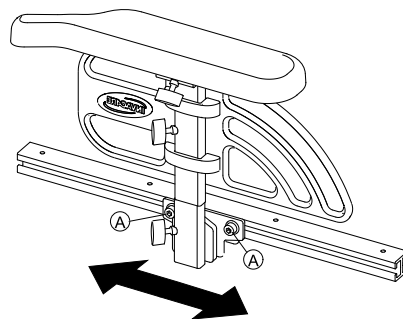

1. Loosen the screws Ⓐ and move the armrest lengthwise.
2. Tighten the screws.

5.8.4 Adjusting the seat width

The telescopic seat support can be adjusted in four stages. The seat width can thus be adjusted together with the adjustable seat plate or the adjustable sling seat.

The description of how the width is adjusted is contained in the service instructions for this mobility device. The service instructions can be ordered from Invacare. However, they contain instructions for specially trained service technicians and describe operations that are not intended for the end user.

5.8.5 Adjusting the seat depth (Modulite seat unit)



The seat depth has a major influence on the selection of the center of gravity of the seat. This impacts its dynamic stability. If you make a major change to the seat depth the center of gravity of the seat must also be adjusted. See "Adjusting the center of gravity of the seat" in the service instructions for this mobility device. The service instructions can be ordered from Invacare. However, they contain instructions for specially trained technicians and describe operations that are not intended for the end user.



The numbers on the scale on the seat serve as a guide. They do not stipulate any dimensions such as seat depth in centimeters.



- 6 mm Allen key

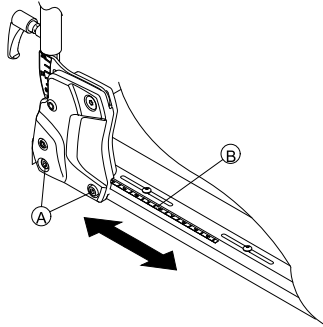

1. On both sides, loosen the bottom backrest screw (A). Do not remove the screws!
2. Move the backrest to the required seat depth. You can adjust the seat depth steplessly. Use scale (B) on the seat as a guide for this purpose. Ensure that the same seat depth is set on both sides.
3. Re-tighten the screws.

5.9 Adjusting the seat angle



CAUTION!

Adjusting the seat tilt or the backrest angle changes the geometry of the mobility device and directly influences its dynamic stability!

- For details regarding dynamic stability, negotiating gradients and obstacles and the correct adjustment of seat tilt or backrest angle, refer to 6.6 *Taking Obstacles*, page 77 and 6.7 *Driving up and down gradients*, page 78.

5.9.1 Electrical

Consult the user manual for your remote for information about electrical adjustment.

5.9.2 Manually using spindle

The seat angle is adjusted by means of a spindle, which is to be found at the front underneath the seat frame.

When adjusting the seat angle it should be ensured that at least 1 cm of the threaded bolt always remains inside the spindle and is not completely unscrewed from the spindle.



It is easier to adjust the angle of the seat when there is nobody sitting in the wheelchair.



The figure shows the position of the spindle (1) for manual seat angle adjustment.

5.10 Adjusting the backrest



CAUTION!

Adjusting the seat tilt or the backrest angle changes the geometry of the mobility device and directly influences its dynamic stability!

– For details regarding dynamic stability, negotiating gradients and obstacles and the correct adjustment of seat tilt or backrest angle, refer to *6.6 Taking Obstacles, page 77* and *6.7 Driving up and down gradients, page 78*.

5.10.1 Electrical

Consult the user manual for your remote for information about electrical adjustment.

5.10.2 Adjusting the backrest (Firm seat)

The angle of the manually adjustable backrest is continuously adjustable between +2° and +22°.



Tools:

- 1 x open-ended spanner 13 mm
- 1 x Phillips screwdriver

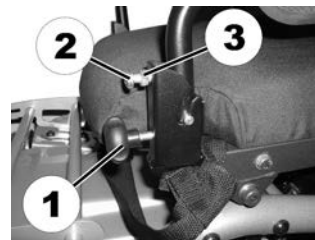

The angle of the manually adjustable backrest is adjusted on both sides by means of an adjustment knob (1) and a limiting screw (2), which is fitted with a counter nut (3).

1. Loosen the knobs (1) on both sides.
2. Loosen the counter nut (3) of the limiting screw (2), using the open-ended spanner 13 mm.
3. Adjust the limiting screws (2) evenly on both sides to the desired backrest angle, using the Phillips screwdriver.
4. Tighten the counter nut (3).
5. Re-tighten the knobs.

5.10.3 Adjusting the backrest (Flex 2 seat unit) — manually using the gas pressure spring



The lever (1) for adjusting the backrest angle is located on the opposite side from the remote under the armrest. If, for example, the remote is installed on the right, the lever is located on the left.

1. Pull the lever upwards. Adjust the backrest to the required angle.
2. Release the lever again.
The backrest engages again.

5.10.4 Adjusting the height of the backrest (Modulite seat unit)

The following section describes the procedures for adjusting the height of the backrest plate.



The sling back is only available in fixed heights of 48 and 54 cm.



- 5 mm Allen key

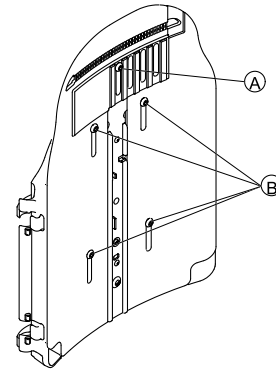

1. Loosen the backrest plate screws Ⓐ and Ⓑ.
Do not remove the screws!
2. Move the backrest plate to the required height.
3. Re-tighten the screws.

5.10.5 Adjusting the width of the backrest (Modulite seat unit)

You can adjust the backrest plate width to a certain degree by adjusting the front plate, e.g. in order to adjust the backrest plate in line with the seat cushion. Fairly large adjustments must be made by a service technician to the rear plate and are outlined in the service instructions for this mobility device.



The sling back is only available in two widths of 38-43 cm and 48-53 cm and, under certain circumstances, must be replaced for a width adjustment. For a replacement description, see the service instructions for this mobility device. The service instructions can be ordered from Invacare. However, they contain instructions for specially trained service technicians and describe operations that are not intended for the end user.

Note that if the sling back width is adjusted the backrest cushion must also be replaced.



- 5 mm Allen key

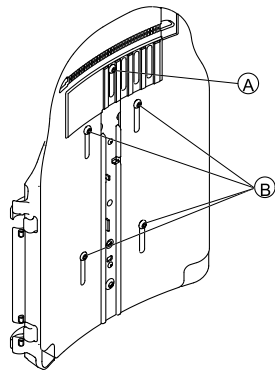

1. Loosen and remove the backrest plate screw (A).
2. Loosen the backrest plate screws (B).
Do not remove the screws!
3. Move the backrest plate halves to the required width.

4. Re-insert screw (A).
5. Re-tighten the screws.

5.10.6 Adjusting the backrest angle (Modulite seat unit)



CAUTION!

Every change to the seat angle and the backrest angle alters the geometry of the power wheelchair and affects its dynamic stability

- For more information on stability, overcoming obstacles correctly, driving along inclines and slopes and the correct position of the backrest and seat angles, see the section 6.6 *Taking Obstacles*, page 77 and 6.7 *Driving up and down gradients*, page 78.



CAUTION!

Risk of falling out of the wheelchair

When adjusting the backrest, it might move backward unexpectedly and you might fall out of the wheelchair.

- Do not rest against the backrest while adjusting it.



If the backrest is fitted with knobs instead of Allen screws, you do not need tools.

Width-adjustable backrest



- 6 mm Allen key

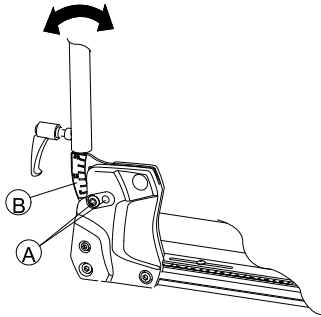

1. On both sides, loosen and remove the upper backrest screw (A).
2. Set the required backrest angle in 3.8° steps. Use scale (B) on the backrest for this purpose. Ensure that you set the same angle on both sides.
3. Re-insert and tighten the screw.
Ensure you insert the screw through one of the holes of the backrest bracket. The screw must be visible on the inside of the bracket and the screw head must be flush with the bracket.

Simple backrest



- 6 mm Allen key
-

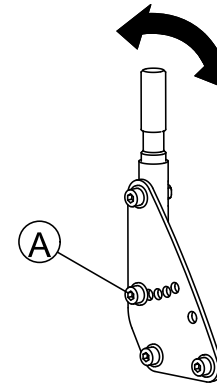

1. On both sides, loosen and remove the middle backrest screw (A).
2. Set the required backrest angle in 7.5° steps. Ensure that you set the same angle on both sides.
3. Re-insert and tighten the screw.

5.10.7 Adjusting the tension adjustable backrest upholstery

1.



Remove the backrest cushion (attached with hook-and-loop straps) by pulling it up and off to access the adjustment straps.

2.



Adjust the tension of the individual straps as desired.

3. Replace the backrest cushion.

5.11 Adjusting the headrest



CAUTION!

Risk of injury during use of the mobility device as a vehicle seat if a headrest is wrongly adjusted or not installed

This can cause the neck to be hyperextended during collisions.

- A headrest must be installed. The headrest optionally supplied for this mobility device by Invacare is perfectly suitable for use during transport.
- The headrest must be adjusted to the user's ear height.

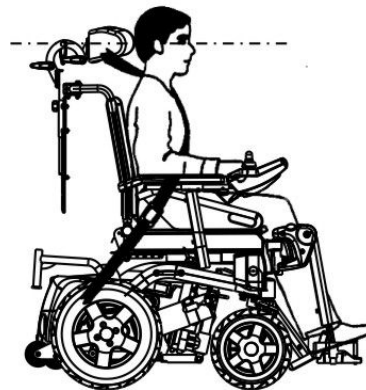

5.11.1 Adjusting the position of the headrest or neckrest

The adjustment of the position is the same for all headrests and neckrests.



- 5 mm Allen key

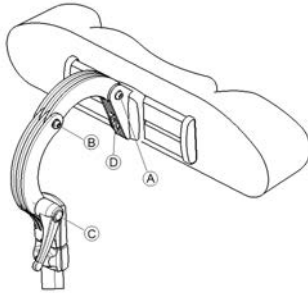

1. Loosen the screws Ⓐ , Ⓑ or the clamping lever Ⓒ.
2. Adjust the headrest or neckrest to the required position.
3. Retighten screws and clamping lever.
4. Loosen the Allen screw Ⓓ.
5. Slide the headrest left or right to the required position.
6. Retighten the Allen screw.

5.11.2 Adjusting the height of the headrest or neckrest

The adjustment of the height is the same for all headrests and neckrests.

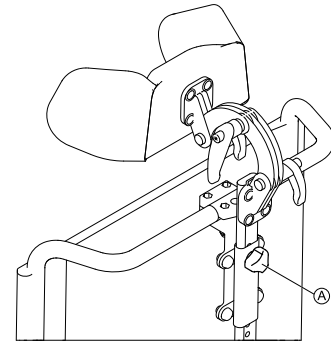

1. Loosen knob Ⓐ.
2. Adjust headrest or neckrest to required height.
3. Retighten knob.

5.11.3 Adjusting the cheek supports



1. Push the cheek supports inward or pull them out to the required position.

5.12 Adjusting the trunk support (Flex 2 seat / Firm seat)

The trunk supports can be adjusted in width, height and depth.

5.12.1 Adjusting the width

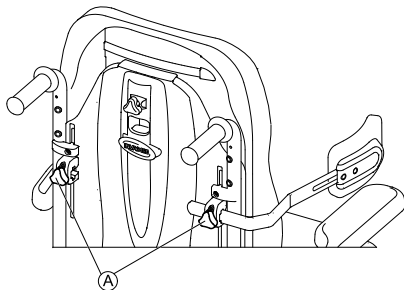

1. Loosen the knobs **A** that hold the lateral supports.
2. Adjust the supports to the desired width.
3. Re-tighten the knobs.

5.12.2 Adjusting the height



- 5 mm Allen key

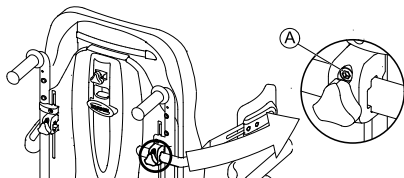

1. Loosen the screws **A** that allow height adjustment of the lateral supports.
2. Adjust the supports to the desired height.
3. Re-tighten the screws.

5.12.3 Adjusting the depth



- 5 mm Allen key

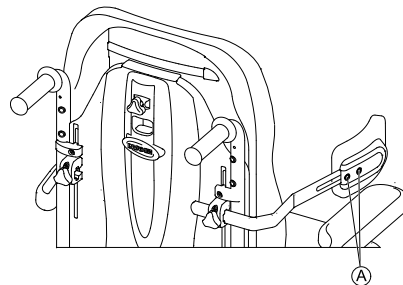

1. Loosen the screws **A** that allows the support pads to slide forwards and backwards.
2. Adjust the supports to the desired position.
3. Re-tighten the screws.

5.13 Adjusting the height-adjustable push handle (Flex 2 seat)

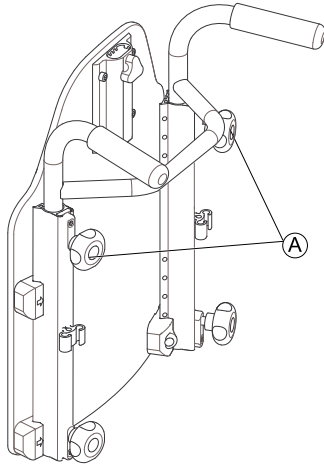

1. Loosen the knobs Ⓐ that hold the push handle.
2. Adjust the handle to the desired height.
3. Re-tighten the knobs.

5.14 Adjusting and removing the tray



CAUTION!

Risk of injury or material damage if a mobility device which is fitted with a tray is transported in a vehicle

– If a tray is fitted, always remove it before transporting the mobility device.

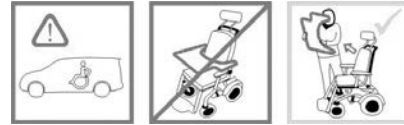

5.14.1 Laterally adjusting the tray

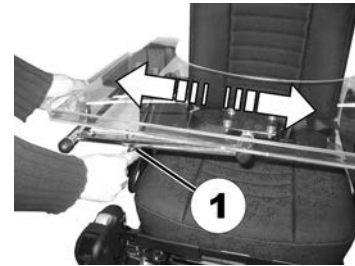

1. Loosen wing-screw (1).
2. Adjust tray towards the left or right.
3. Re-tighten wing-screw.

5.14.2 Adjusting the depth of the tray / removing the tray

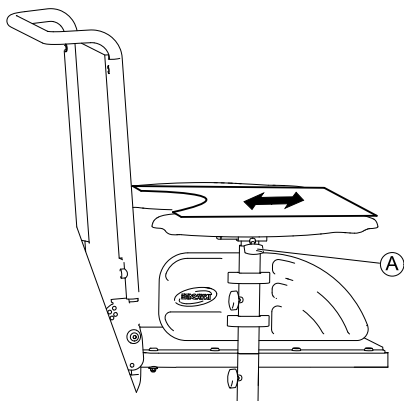

1. Loosen wing-screw (A).
2. Adjust tray to desired depth (or remove it entirely).
3. Re-tighten screw.

5.14.3 Swinging the tray away to the side

The tray can be swivelled up and away to the side to allow the user to get in and out of the mobility device.



CAUTION!

Risk of injury! When the tray is raised it does not lock in place in this position!

- Do not tilt the tray up and leave it leaning in this position.
- Never attempt to drive with the tray tilted up.
- Always lower the tray in a controlled manner.

5.15 Vari-F footrest

5.15.1 Swivelling the footrest/legrest outward and/or removing

The small unlocking button is located on the upper section of the footrest/legrest. When the footrest/legrest is unlocked, it can be swivelled inward or outward when getting into the wheelchair as well as being removed completely.



1. Press the unlocking button (1) and swivel the footrest/legrest outward.
2. Remove the footrest/legrest in an upward direction.

5.15.2 Setting the angle



CAUTION!

Risk of injury due to incorrect adjustment of the footrests and legrests

- Before and during every journey it is imperative to ensure that the legrests contact neither the caster wheels nor the ground.



- 6 mm Allen key

1.



Loosen the screw (1) using the Allen key.

2. If the footrest cannot be moved after loosening the screw, position a metal pin in the designated borehole (2) and use a hammer to knock on this lightly. The clamping mechanism in the interior of the footrest will be released by this. Repeat the procedure from the other side of the footrest if necessary.

3.

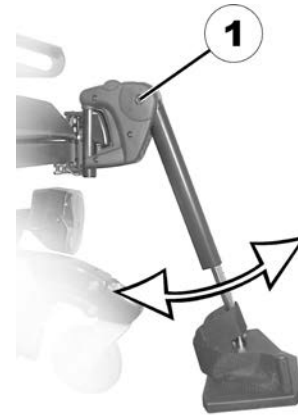

Loosen the screw (1) using the Allen key.

4. Set the desired angle.
5. Re-tighten the screw.

5.15.3 Setting the end stop of the footrest



- 6 mm Allen key
- 10 mm wrench

1.



Fig. 5-4

The end position of the footrest is determined by means of a rubber stop (1).

2.

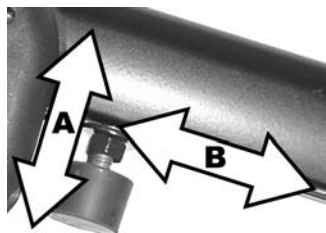

Fig. 5-5

The rubber stop can be screwed in or out (A) or pushed up or down (B).

3.

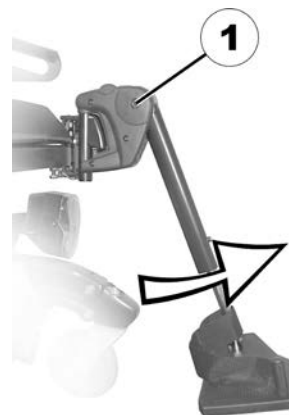

Fig. 5-6

Use the Allen key to loosen the screw (1) and swivel the footrest upward in order to access the rubber stop.

4.



Fig. 5-7

Use the open-ended spanner to loosen the counter nut (1).

5.

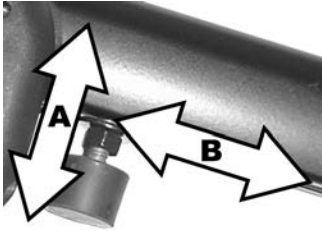

Fig. 5-8

Move the rubber stop to the desired position.

6. Re-tighten the counternut.

7.



Fig. 5-9

Move the footrest to the desired position.

8. Re-tighten the screw.

5.15.4 Adjusting the length of the footrest



CAUTION!

Risk of injury due to incorrect adjustment of the footrests and legrests

– Before and during every journey it is imperative to ensure that the legrests contact neither the caster wheels nor the ground.



- 5 mm Allen key

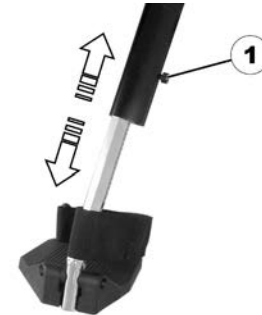

1. Use the spanner to loosen the screw (1).
2. Adjust to the desired length.
3. Re-tighten the screw.

5.16 Vari-A legrests

5.16.1 Swivelling the footrest/legrest outward and/or removing

The small unlocking button is located on the upper section of the footrest/legrest. When the footrest/legrest is unlocked,

it can be swivelled inward or outward when getting into the wheelchair as well as being removed completely.

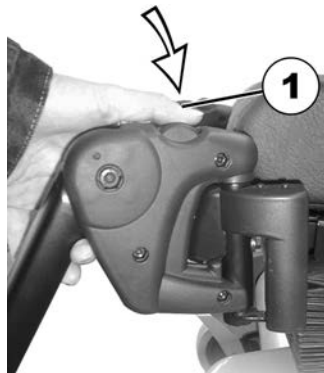

1. Press the unlocking button (1) and swivel the footrest/legrest outward.
2. Remove the footrest/legrest in an upward direction.

5.16.2 Setting the angle



CAUTION!
Risk of injury due to incorrect adjustment of the footrests and legrests

– Before and during every journey it is imperative to ensure that the legrests contact neither the caster wheels nor the ground.

1.

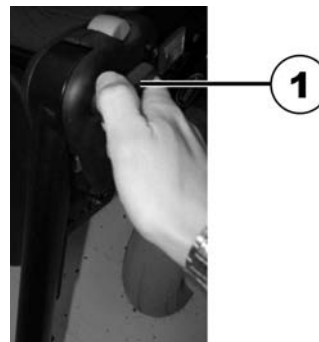

Loosen the locking knob (1) counter-clockwise at least one turn.

2.



Hit the knob to release the locking mechanism.

3.



Set the desired angle.

4.



Turn the knob clockwise to tighten it.

5.16.3 Setting the end stop of the legrest



- 10 mm wrench

1.



The end position of the legrest is determined by means of a rubber stop (1).

2.

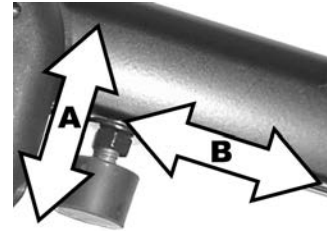

The rubber stop can be screwed in or out (A) or pushed up or down (B).

3.

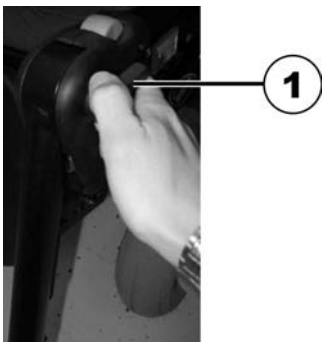

Loosen the locking knob (1) counter-clockwise at least one turn.

4.



Hit the knob to release the locking mechanism.

5.



Swivel the legrest upward in order to access the rubber stop.

6.



Use the wrench to loosen the conical nut (1).

7.

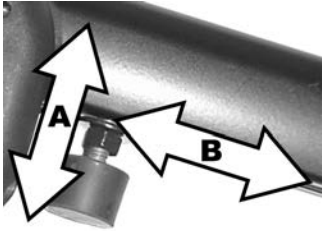

Move the rubber stop to the desired position.

8. Re-tighten the counternut.

9.



Move the legrest to the desired position.

10. Re-tighten the locking knob.

5.16.4 Adjusting the length of the legrest



CAUTION!

Risk of injury due to incorrect adjustment of the footrests and legrests

– Before and during every journey it is imperative to ensure that the legrests contact neither the caster wheels nor the ground.



- 5 mm Allen key

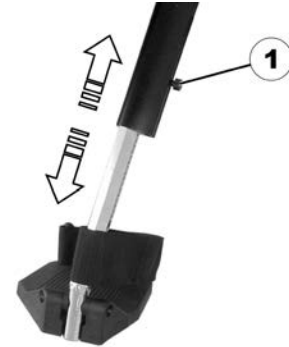

1. Use the spanner to loosen the screw (1).
2. Adjust to the desired length.
3. Re-tighten the screw.

5.16.5 Adjusting the depth of the calf pad

The depth of the calf pad can be adjusted via the holding plate. The holding plate hole combinations allow 5 different depth settings.



- 10 mm wrench

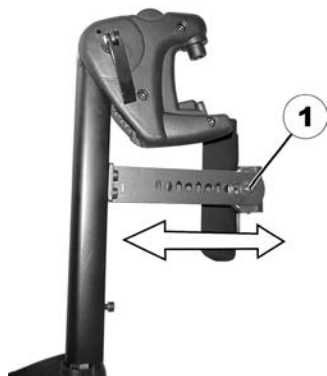

1. Use the wrench to loosen the nut (1) and remove.
2. Adjust to the desired depth. Observe that the round holes are intended for the calf pad retaining screw and the oblong holes for the aglet without thread.
3. Screw the nut back on and tighten.

5.16.6 Adjusting the height of the calf pad



- 4 mm Allen key



1. Use the Allen key to loosen the screws (1).
2. Adjust to the desired position.
3. Re-tighten the screws.

5.16.7 Unlocking and swivelling the calf pad backward when alighting

- 1.



Press the calf pad straight down.

- 2.



Unlock the legrest and swivel outward.
The calf pad swivels backward on its own.

3.



Lift leg over the heel strap and place on the ground.

5.16.8 Adjusting the angle-adjustable foot plate



- 5 mm Allen key

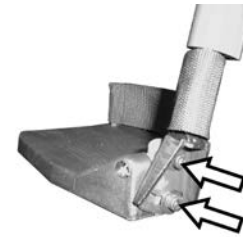

1. Use the Allen key to loosen both set screws on the foot plate.
2. Adjust to the desired angle.
3. Re-tighten the screws.

5.16.9 Adjusting the angle- and depth-adjustable foot plate



- 5 mm Allen key



1. Use the Allen key to loosen the set screw on the foot plate (1).
2. Adjust the foot plate to the desired angle or depth.
3. Re-tighten the screw.

5.17 Powered elevating legrests (ADE legrests)

5.17.1 Swivelling the legrest outward and/or removing

The small unlocking button is located on the upper section of the legrest. When the legrest is unlocked, it can be swivelled inward or outward when getting into wheelchair as well as being removed completely.



1. Press the unlocking button (1) and swivel the legrest outward.
2. Remove the legrest in an upward direction.

5.17.2 Setting the angle



CAUTION!
Risk of crushing

- Do not reach inside the swivelling range of the legrest.



CAUTION!

Risk of injury due to incorrect adjustment of the footrests and legrests

- Before and during every journey it is imperative to ensure that the legrests contact neither the caster wheels nor the ground.

The electrically height-adjustable legrests are operated using the remote. Refer to the separate user manual for your remote for more information.

5.17.3 Adjusting the length of the legrest



CAUTION!

Risk of injury due to incorrect adjustment of the footrests and legrests

- Before and during every journey it is imperative to ensure that the legrests contact neither the caster wheels nor the ground.



- 10 mm wrench

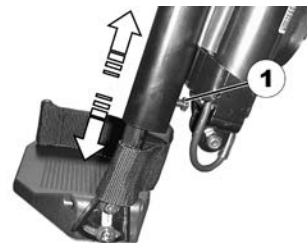

1. Use the wrench to loosen the screw (1).
2. Adjust to the desired length.
3. Re-tighten the screw.

5.17.4 Adjusting the depth of the calf pad

The depth of the calf pad can be adjusted via the holding plate. The holding plate hole combinations allow 5 different depth settings.

-
-  • 10 mm wrench
-

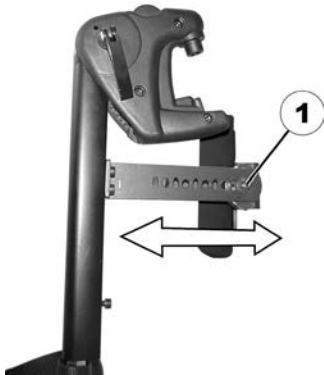

1. Use the wrench to loosen the nut (1) and remove.
2. Adjust to the desired depth. Observe that the round holes are intended for the calf pad retaining screw and the oblong holes for the aglet without thread.
3. Screw the nut back on and tighten.

5.17.5 Adjusting the height of the calf pad

-
-  • 4 mm Allen key
-



1. Use the Allen key to loosen the screws (1).
2. Adjust to the desired position.
3. Re-tighten the screws.

5.17.6 Unlocking and swivelling the calf pad backward when alighting

- 1.



2. Press the calf pad straight down.



Unlock the legrest and swivel outward.
The calf pad swivels backward on its own.

3.



Lift leg over the heel strap and place on the ground.

5.17.7 Adjusting the angle-adjustable foot plate

-  • 5 mm Allen key
-

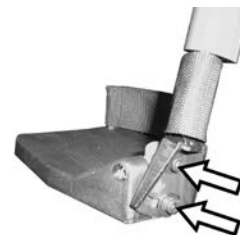

1. Use the Allen key to loosen both set screws on the foot plate.
2. Adjust to the desired angle.
3. Re-tighten the screws.

5.17.8 Adjusting the angle- and depth-adjustable foot plate

-  • 5 mm Allen key
-



1. Use the Allen key to loosen the set screw on the foot plate (1).
2. Adjust the foot plate to the desired angle or depth.
3. Re-tighten the screw.

5.18 Standard 80° footrest

5.18.1 Swivel the footrests outwards and/or remove them



The small release lever is to be found in the upper part of the legrest (1). When the legrest is released it can be swivelled inward or outward to facilitate access and also be removed completely.



1. Push the release lever inward or outward. The legrest is released.
2. Swivel the legrest inward or outward.
3. To remove the legrest simply pull upward.

5.18.2 Adjusting the length



- 5 mm Allen key



1. Loosen the screw (1) using the Allen key, but do not remove completely.
2. Set the legrest to the desired length.
3. Re-tighten the screw.

5.19 Manually height-adjustable legrest

5.19.1 Swivelling the legrest outward and/or removing

The unlocking knob is located on the top section of the legrests. When the legrest is unlocked, it can be swivelled to the inside or outside to facilitate getting in, or can be completely removed.

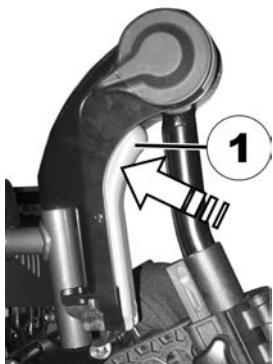

1. Press unlocking knob (1) and remove legrests upwards.

5.19.2 Setting the angle



CAUTION!

Risk of crushing

- Do not reach inside the swivelling range of the legrest.



CAUTION!

Risk of injury due to incorrect adjustment of the footrests and legrests

- Before and during every journey it is imperative to ensure that the legrests contact neither the caster wheels nor the ground.



1. Press the unlocking lever (1) down. Adjust the legrest to the required angle.
2. Release the unlocking lever. The legrest engages.

5.19.3 Adjusting the length of the legrest



CAUTION!

Risk of injury due to incorrect adjustment of the footrests and legrests

- Before and during every journey it is imperative to ensure that the legrests contact neither the caster wheels nor the ground.



- 5 mm Allen key

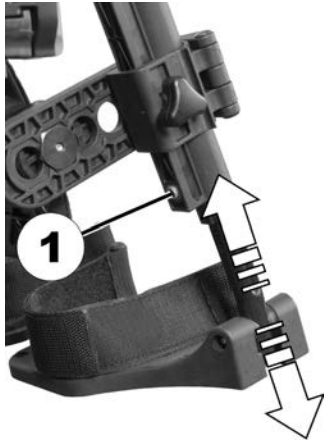

1. Loosen bolt (1) with the Allen key.
2. Adjust to required length.
3. Retighten screw.

5.19.4 Adjusting the depth of the calf pad

The calf pad has four depth settings.



- 4 mm Allen key

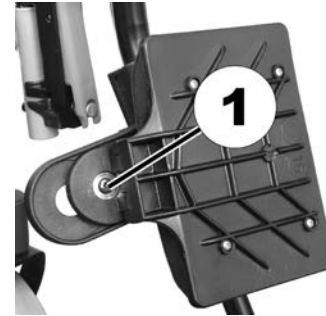

1. Swivel the calf pad to the front.
2. Release bolt (1) with the Allen key and remove.
3. Set the nut on the other side to the required depth.
4. Adjust the calf pad to match the depth of the nut, put the screw back in and tighten.

5.19.5 Adjusting the height of the calf pad

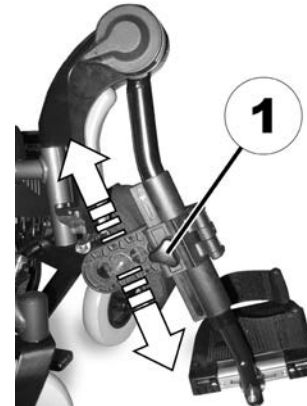

1. Loosen the hand screw (1).
2. Adjust to required position.
3. Retighten the wing nuts.

5.20 Adjusting the width of the legrests fixed to the side (Flex 2 seat / Modulite seat)

-  • 13 mm wrench (Modulite seat)
• 10 mm wrench (Flex 2 seat)



The screws that allow width adjustment of side-mounted legrests are located under the seat (1).

1. Loosen the screws using the open-end spanner.
2. Adjust the legrest to the desired position.
3. Re-tighten the screws.

5.21 Legrests for the Firm seat

5.21.1 Modifying the front seat depth by adjusting the legrest support brackets

The seat depth in the front can be modified by adjusting the position of the legrest support brackets. Adjusting the position of the legrest support brackets is the same for all types of legrests.



Tools:

- 1 x Allen key 4 mm

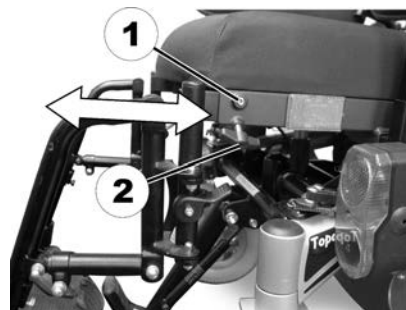

1. Loosen the grub screw (1), using the Allen key.
2. Release the wing screw (2).
3. Set the position of the legrest support bracket to the desired depth.
4. Re-tighten the screws.

5.21.2 Adjusting the length of the legrest — Standard / Junior / Mini Legrests (Firm seat)



CAUTION!

Risk of injury due to incorrect adjustment of the footrests and legrests

- Before and during every journey it is imperative to ensure that the legrests contact neither the caster wheels nor the ground.



Tools:

- 1 x open-ended spanner 13 mm



1. Remove the plastic cover cap from the adjustment screw (1).
2. Loosen the screw, using the open-ended spanner 13 mm.
3. Set the legrest to the desired length. Take care not to rotate the lower part of the legrest in its support tube.
4. Re-tighten the screws.
5. Re-position the plastic cover cap.

5.21.3 Adjusting the angle of the legrest — Angle adjustable legrest



Tools:

- 1 x open-ended spanner 13 mm
- 1 x open-ended spanner 10 mm
- 1 x Allen key 4 mm

1.

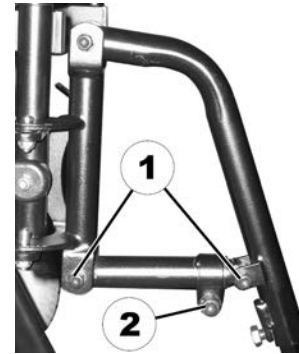

- Loosen the fixation screws (1) of the pivotal points of the angle adjustment, using the open-ended spanner 10 mm and the Allen key 4 mm.
2. Loosen the clamping screw (2) of the angle adjustment, using the open-ended spanner 13 mm.

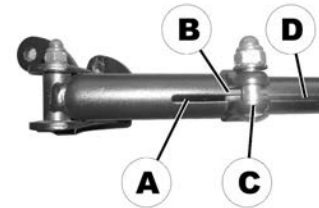

On the underside of the legrest hanger there is a slit (A) in the outer tube, which allows visual inspection.

When adjusting the angle, the inner tube (D) should only ever be pulled out so far that its end is flush with the edge (B) of the clamp (C).

3.

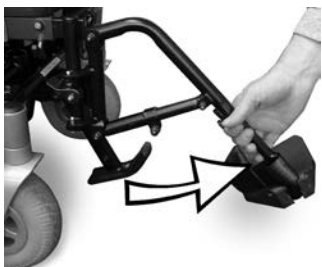

Adjust legrest to the desired angle.

4. Check the remaining length of the inner tube in the outer tube through the slit for visual inspection.
5. Re-tighten all screws.

5.21.4 Adjusting the length of the legrest — Angle adjustable legrest



CAUTION!

Risk of injury due to incorrect adjustment of the footrests and legrests

– Before and during every journey it is imperative to ensure that the legrests contact neither the caster wheels nor the ground.



Tools:

- 1 x open-ended spanner 13 mm



1. Loosen the screw (1).
2. Set the legrest to the desired length. Take care not to rotate the lower part of the legrest in its support tube.
3. Re-tighten the screw.

6 Usage

6.1 Driving



The maximum load capacity that is stated in the technical data only states that the system is designed for this mass in total. However, this does not mean that one can sit a person with this body weight in the mobility device without restrictions. Attention must be paid to the body proportions, such as height, weight distribution, abdominal belt, leg and calf strap and seat depth. These factors have a strong influence on driving features such as tilt stability and traction. The permissible axle loads in particular must be adhered to (refer to *11 Technical Data, page 103*). It may possibly be necessary to carry out adaptations to the seat system.

6.2 Before driving for the first time

Before you take your first trip, you should familiarize yourself well with the operation of the mobility device and with all operating elements. Take your time to test all functions and driving modes.



If installed, make sure to properly adjust and use the posture belt each time you use the mobility device.

Sitting comfortably = Driving safely

Before each trip, make sure that:

- You are within easy reach of all operating controls.
- The battery charge is sufficient for the distance intended to be covered.

- The posture belt (if installed) is in perfect order.
- The rear mirror (if installed) is adjusted so you can look behind at all times without having to bend forward or shift your seating position.

6.3 Parking and stationary

When parking your vehicle or if your vehicle is stationary for a prolonged period:

1. Switch the vehicle's power system off (ON-/OFF key).
2. Activate your anti-theft lock, if existing.

6.3.1 Activating and deactivating the manual wheel lock

The motors of the mobility device are equipped with automatic brakes, preventing that the mobility device starts rolling out of control when the joystick box is switched off.

Your mobility device can also be fitted with manual wheel locks in addition to the motor brakes. These prevent the mobility device from rocking during transport, for example in the case of play in the transmission.

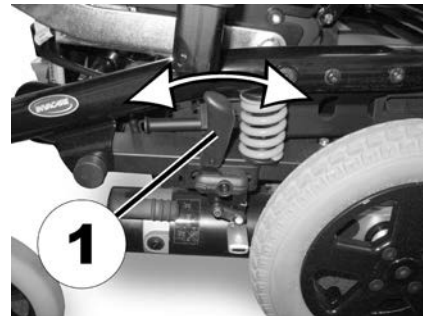

Engaging the manual wheel lock

1. Press lever (1) forward.

Disengaging the manual wheel lock

1. Pull lever (1) backwards.

6.4 Getting in and out of the mobility device

- ! – The armrest must be removed or swiveled up in order to get into or out of the mobility device from the side.

6.4.1 Removing the armrests in order to side transfer (Standard seat / Firm seat / Modulite seat)

The armrest is either fixed with a locking pin or a locking screw, depending on the version. If you intend to get into the mobility device on the side that the remote is on, then depending on the remote version you may be able to detach the remote cable.

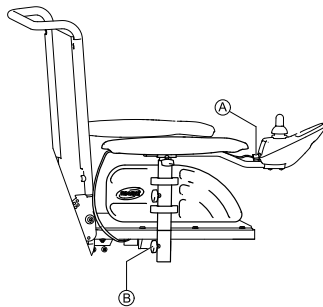

1. Pull the plug (A) of the remote cable to disconnect the remote.
2. Loosen wing nut (B).
3. Remove the armrest from the holder.

6.4.2 Removing the armrests in order to side transfer (Flex 2 seat)

The armrest is either fixed with a locking pin or a locking screw, depending on the version. If you intend to get into the mobility device on the side that the remote is on, then depending on the remote version you may be able to detach the remote cable.

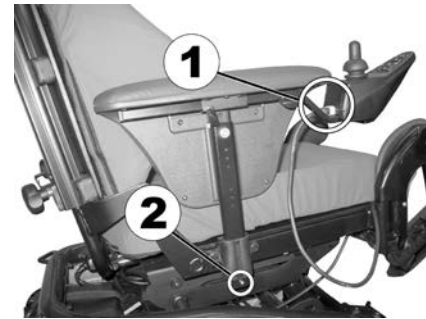

1. Pull the plug (1) of the remote cable to disconnect the remote.
2. Push the locking pin (2) in.
3. Remove the armrest from the holder.

6.4.3 Information about getting in and out



WARNING!

Risk of serious injury or damage

Improper transfer techniques may cause serious injury or damage

- Before attempting transfers, consult a healthcare professional to determine proper transfer techniques for the user and type of wheelchair.
- Follow the instructions below.



If you do not have sufficient muscle strength, you should ask other persons for help. Use a sliding board, if possible.

Getting into the mobility device:

1. Position your mobility device as close as possible to your seat. This might have to be done by an attendant.
2. Align casters parallel to the drive wheels to improve stability during transfer.
3. Always switch your mobility device off.
4. Always engage both motor locks/clutches and free wheel hubs (if fitted) to prevent the wheels from moving.
5. Depending on the armrest type of your mobility device, detach the armrest or swivel it up.
6. Now slide into the mobility device.

Getting out of the mobility device:

1. Position your mobility device as close as possible to your seat.
2. Align casters parallel to the drive wheels to improve stability during transfer.
3. Always switch your mobility device off.
4. Always engage both motor locks/clutches and free wheel hubs (if fitted) to prevent the wheels from moving.
5. Depending on the armrest type of your mobility device, detach the armrest or swivel it up.
6. Now slide onto your new seat.

6.4.4 Swivelling Nucleus Midline Holder to Side

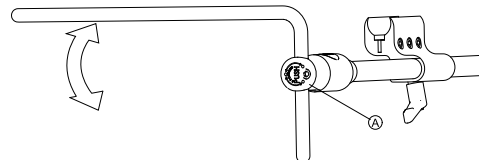

1. Push button **A** and swivel up or down nucleus.

6.4.5 Swivelling Swing-Away Display Holder to Side



The swing-away display holder only locks in place when swivelled to its default position.

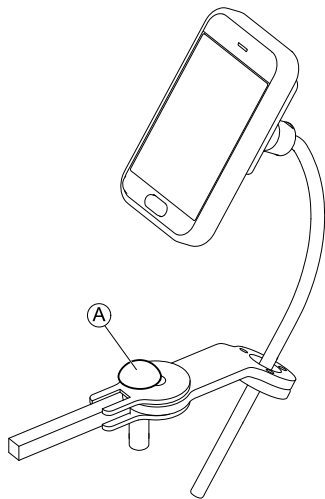

1. Push knob Ⓐ and swivel display holder to side.

6.4.6 Swivelling Chin Control to Side

- 1.

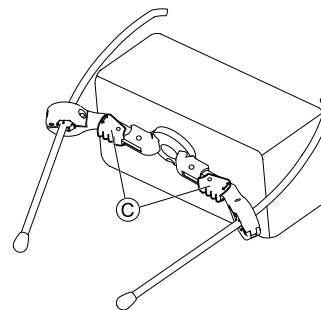

Press locking device Ⓒ (behind headrest) and swivel joystick or egg switch inwards or outwards until it clicks in place.

6.5 Folding away/releasing the curb climber

The curb climber can be folded away to make it easier to front transfer. It can also be folded away when transporting the mobility device to reduce the size of the base.

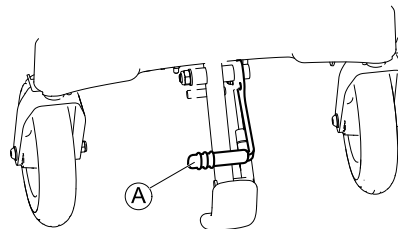

Folding away the curb climber

1. Pull the lever Ⓐ on the curb climber to fold it away.

Releasing the curb climber

1. Push down the lever of the curb climber to release it.

6.6 Taking Obstacles

6.6.1 Maximum obstacle height

You can find information about maximum obstacle heights in the chapter entitled *11 Technical Data, page 103*

6.6.2 Safety information when taking obstacles



CAUTION!

Risk of tipping over

- Never approach obstacles at an angle but at 90 degrees as shown below.
- Approach obstacles followed by a gradient with caution. If unsure whether the gradient is too steep or not, move away from the obstacle and if possible try to find another location.
- Never approach obstacles on an uneven and/or loose ground.
- Never drive with too low tire pressure.
- Put your backrest into an upright position before ascending an obstacle.



CAUTION!

Risk of falling out of the mobility device and damage to the mobility device such as broken casters

- Never approach obstacles that are higher than the maximum climbable obstacle height.
- Never let the footrest/legrest touch the ground when descending an obstacle.
- If unsure whether taking an obstacle is possible or not, move away from the obstacle and if possible find another location.

6.6.3 The correct way to take obstacles



The following instructions how to take obstacles also apply for attendants if the mobility device is fitted with an attendant control.

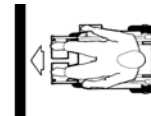

Fig. 6-1 Right

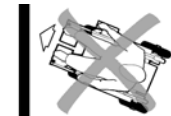

Fig. 6-2 Wrong

Ascending

1. Approach the obstacle or the curb slowly, head-on and at a right angle.
2. Depending on the wheel drive type, stop in one of the following positions:
 - a. In the case of centrally driven mobility devices: 5 - 10 cm before the obstacle.
 - b. For all other drives: approx. 30 - 50 cm in front of the obstacle.

3. Check the position of the front wheels. They must be in driving direction and at right angles to the obstacle.
4. Approach slowly and keep at a consistent speed until the rear wheels have also passed over the obstacle.

Ascending obstacles with a curb climber

1. Approach the obstacle or the curb slowly, head-on and at a right angle.
2. Stop in the following position: 30 – 50 cm in front of the obstacle.
3. Check the position of the front wheels. They must be in driving direction and at right angles to the obstacle.
4. Approach with full speed until the curb climber makes contact with the obstacle. The impetus will lift both front wheels over the obstacle.
5. Keep at a consistent speed until the rear wheels have also passed over the obstacle.

Descending

The approach to descend an obstacle is the same as to ascend it with the difference that you need not to stop before descending.

1. Descend the obstacle with medium speed.



When descending an obstacle too slowly it could happen that the antitippers get stuck and lift the drive wheels off the ground. Driving the mobility device is then no longer possible.

6.7 Driving up and down gradients

For information concerning the maximum safe slope, refer to *11 Technical Data, page 103*



CAUTION!

Risk of tipping over

- Only ever drive downhill at a maximum of 2/3 of the top speed. Avoid sudden changes of direction or abrupt braking when driving on slopes.
- Always return the backrest of your seat or the seat tilt (if adjustable seat tilt is available) to an upright position before ascending slopes. We recommend that you position the seat backrest or the seat tilt slightly to the rear before descending slopes.
- Always lower the lifter (if fitted) to its lowest position before ascending or descending a slope.
- Never attempt to ascend or descend a slope on slippery surfaces or where there is a risk of skidding (such as wet pavement, ice etc).
- Avoid trying to get out of the vehicle on an incline or a gradient.
- Always drive straight in the direction the road or path you are on goes, rather than attempting to zigzag.
- Never attempt to turn around on an incline or a slope.



CAUTION!

Braking distance is much longer on a downhill slope than on even terrain

- Never drive down a slope that exceeds the rated slope (refer to *11 Technical Data, page 103*).

6.8 Handling the drive lock-out feature

Drive lock-out is a feature designed to prevent the wheelchair from being driven after the seating system has been tilted beyond the safe total angle relative to the vertical position. The total angle can be any combination of seat angle, backrest angle and/or surface angle.



WARNING!

Risk of tipping

Drive lock-out only responds when you adjust angles in standstill. The feature CANNOT identify angle changes during driving, for example, when accessing a slope.

– Stop your wheelchair before driving on a slope, set the total angle to a value including the angle of the slope you want to access. Start driving. If the drive lock-out allows driving then it is safe to drive on the slope with the original seat and backrest angles set.



When you set the seat angle and the backrest angle according to our recommendations before driving on a slope, you can safely drive on slopes. Refer to *2 Safety, page 10*.

Depending on the type of your remote, one of the following will occur when the drive lock-out feature has been activated:

- A minus symbol displays on the remote
- A crossed out drive profile number displays on the remote
- Left to right chase on the battery display

- Left to right chase on the battery display alternating with a steady display

For details on what your remote displays, refer to the user manual of the remote.

Checking drive lock-out on a slope

If you are unsure whether the angle setting of your wheelchair is within the safe range when driving on a slope, do the following:

1. Stop the wheelchair and switch to adjust mode and back to drive mode.
2. Start driving.
If the total angle is outside of the safe range, the drive lock-out will inhibit driving. Adjust the angle as described below.

Adjusting the total angle to allow driving

1. Reduce the seat angle and/or the backrest angle to set the total angle to a value within the safe range.
2. Start driving.
If the total angle is within the safe range, the wheelchair moves.



6.9 Use on public roads

If you wish to use your mobility device on public roads and lighting is required by national legislation, then your mobility device needs to be fitted with an appropriate lighting system.

Contact your Invacare provider if you have any questions.

6.10 Pushing the mobility device in freewheel mode

The motors of the mobility device are equipped with automatic brakes, preventing that the mobility device starts rolling out of control when the remote is switched off. When pushing the mobility device manually whilst freewheeling, the magnetic brakes must be disengaged.

-  Pushing the mobility device by hand may require more physical force than expected (more than 100 N). The necessary force nevertheless complies with the requirements of ISO 7176-14.
-  The intended use of the freewheel mode is to maneuver the mobility device over short distances. The push handles or push bars support this function, but be aware that there might be some impairment between the feet of the assistant and the rear part of the mobility device.

6.10.1 Disengaging motors (conventional motors)



CAUTION!

Risk of injury from hot motor surfaces

- Avoid touching the motor surfaces when engaging or disengaging.



CAUTION!

Risk of the mobility device running away

- When the motors are disengaged (for push operation whilst freewheeling), the electromagnetic motor brakes are deactivated. When the mobility device is parked, the levers for engaging and disengaging the motors must without fail be locked firmly into the "DRIVE" position (electromagnetic motor brakes activated).



The motors may only be disengaged by an attendant, not by the user.

This ensures that the motors are only disengaged if an attendant is available to secure the wheelchair and prevent unintended rolling.

Each motor is fitted with an engaging turn knob which is used to engage or disengage the motor.

Disengaging the motor:



1. Switch off remote.
2. Turn the engaging turn knob (A) clockwise.
The motor is disengaged.

Engaging the motor:

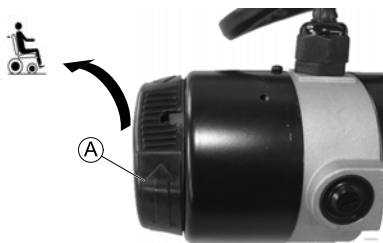

1. Turn the engaging turn knob (A) counterclockwise.
The motor is engaged.
-  Both motors must always be engaged before driving!

7 Controls system

7.1 Controls protection system

The wheelchair controls system is fitted with an overload protection.

If the drive is severely overloaded over a long period of time (for example, when driving up a steep hill) and especially when the ambient temperature is high, the controls system could overheat. In this case, the wheelchair performance is gradually reduced until it comes to a halt. The status display shows a corresponding error code (refer to the user manual for your remote). By switching the power supply off and back on again, the error code is cleared and the controls system is switched back on. It can however take up to five minutes until the controls system has cooled down enough for the drive to restore full performance again.

If the drive is stalled by an insurmountable obstacle, for example, a curb or similar which is too high, and the driver attempts driving for more than 20 seconds against this obstacle, the controls system automatically switches off to prevent the motors from being damaged. The status display shows a corresponding error code (refer to the user manual of your remote). By switching off and back on again, the error code is cleared and the controls system is switched back on.



A defective main fuse may be replaced only after checking the entire controls system. A specialized Invacare provider must perform the replacement. You can find information on the fuse type in *11 Technical Data, page 103*

7.2 Batteries

Power is supplied by two 12 V batteries. The batteries are maintenance-free and only need regular charging.

In the following, you find information on how to charge, handle, transport, store, maintain, and use batteries.

7.2.1 General information on charging

New batteries should always be fully charged once before their first use. New batteries will be at their full capacity after having run through approx. 10 - 20 charging cycles (break-in period). This break-in period is necessary to fully activate the battery for maximum performance and longevity. Thus, range and running time of your mobility device could initially increase with use.

Gel/AGM lead acid batteries do not have a memory effect as NiCd batteries.

7.2.2 General instructions on charging

Follow the instructions listed below to ensure safe use and longevity of the batteries:

- Charge 18 hours prior to initial usage.
- We recommend charging the batteries daily after every discharge even after partly discharge, as well as each night over night. Depending on the level of discharge, it can take up to 12 hours until the batteries are fully charged again.
- When the battery indicator reached the red LED range, charge the batteries for 16 hours minimum, neglecting the charge complete display!
- Try to provide a 24 hour charge once a week to make sure that both batteries are fully charged.

- Do not cycle your batteries at a low state of charge without regularly recharging them fully.
- Do not charge your batteries under extreme temperatures. High temperatures above 30 °C are not recommended for charging as well as low temperatures below 10 °C.
- Use only charging devices in Class 2. This class of chargers may be left unattended during charging. All charging devices which are supplied by Invacare comply with these requirements.
- You cannot overcharge the batteries when using the charger supplied with your mobility device, or a charger that has been approved by Invacare.
- Protect your charger from sources of heat such as heaters and direct sunlight. If the battery charger overheats, charging current will be reduced and the charging process delayed.

7.2.3 How to charge the batteries

Refer to the user manuals for your remote and battery charger for the position of the charging socket and further information about charging the batteries.



WARNING!

Risk of explosion and destruction of batteries if the wrong battery charger is used

- Only ever use the battery charger supplied with your mobility device, or a charger that has been approved by Invacare.



WARNING!

Risk of electric shock and damage to the battery charger if it gets wet

- Protect the battery charger from water.
- Always charge in a dry environment.



WARNING!

Risk of short circuit and electric shock if the battery charger has been damaged

- Do not use the battery charger if it has been dropped or damaged.



WARNING!

Risk of electric shock and damage to the batteries

- NEVER attempt to recharge the batteries by attaching cables directly to the battery terminals.



WARNING!

Risk of fire and electric shock if a damaged extension cable is used

- Only ever use an extension cable if it is absolutely necessary. In case you must use one, make sure it is in good condition.

**WARNING!****Risk of injury if using the mobility device during charging**

- DO NOT attempt to recharge the batteries and operate the mobility device at the same time.
- DO NOT sit in the mobility device while charging the batteries.

1. Switch off the mobility device.
2. Connect the battery charger to the charger socket.
3. Connect the battery charger to the power supply.

7.2.4 How to disconnect the mobility device after charging

1. Once charging is complete, first disconnect the battery charger from the power supply, then disconnect the plug from the remote.

7.2.5 Storage and Maintenance

Follow the instructions listed below to ensure safe use and longevity of the batteries:

- Always store the batteries fully charged.
- Do not leave the batteries in a low state of charge for an extended length of time. Charge a discharged battery as soon as possible.
- In case your mobility device is not used for a longer period of time (that is more than two weeks), the batteries must be charged at least once a month to maintain a full charge and always be charged before use.
- Avoid hot and cold extremes when storing. We recommend to store batteries at a temperature of 15 °C.

- Gel and AGM batteries are maintenance-free. Any performance issues should be handled by a properly trained mobility device technician.

7.2.6 Instructions on using the batteries**CAUTION!****Risk of damaging the batteries.**

- Avoid ultra-deep discharges and never drain your batteries completely.

- Pay attention to the Battery Charge Indicator! Charge the batteries when the Battery Charge Indicator shows that battery charge is low.
How fast the batteries discharge depends on many circumstances, such as ambient temperature, condition of the surface of the road, tire pressure, weight of the driver, way of driving and utilisation of lighting, if fitted.
- Try to charge the batteries always before you reach the red LED range.
The last 3 LED (two red and one orange) mean a remaining capacity of about 15 %.
- Driving with flashing red LED's means an extreme stress for the battery and should be avoided under normal circumstances.
- When only one red LED is flashing, the Battery Safe feature is enabled. From this time, speed and acceleration is reduced drastically. It will allow you to move the mobility device slowly out of a dangerous situation before the electronic finally cuts off. This is deep discharging and should be avoided.

- Be aware that for temperatures below 20 °C, the nominal battery capacity starts to decline. For example, at -10 °C the capacity is reduced to about 50 % of the nominal battery capacity.
- To avoid damaging the batteries, never allow them to be fully discharged. Do not drive on heavily discharged batteries if it is not absolutely necessary, as this will strain the batteries unduly and shorten their life expectancy.
- The earlier you recharge the batteries, the longer they live.
- The depth of discharge affects the cycle life. The harder a battery has to work, the shorter is its life expectancy. Examples:
 - One deep discharge stresses the same as 6 normal cycles (green /orange display off).
 - The battery life is about 300 cycles at 80 % discharge (first 7 LED off), or about 3000 cycles at 10 % discharge (one LED off).



The number of LED can vary depending on the remote type.

- Under normal operation, once a month the battery should be discharged until all green and orange LED are off. This should be done within one day. A 16 hour charge afterwards is necessary as reconditioning.

7.2.7 Transporting batteries

The batteries supplied with your mobility device are not hazardous goods. This classification is based on the German GGVS Hazardous Goods Road Transport Ordinances, and the IATA/DGR Hazardous Goods Rail Transport / Air Transport Ordinances. Batteries may be transported without

restrictions, whether by road, rail or by air. Individual transport companies have, however, guidelines which can possibly restrict or forbid certain transport procedures. Please ask the transport company regarding each individual case.

7.2.8 General instructions on handling the batteries

- Never mix and match different battery manufactures or technologies, or use batteries that do not have similar date codes.
- Never mix gel with AGM batteries.
- The batteries reach their end of life when the drive range is significantly smaller than usual. Contact your provider or service technician for details.
- Always have your batteries installed by a properly trained mobility device technician or a person with adequate knowledge. They have the necessary training and tools to do the job safely and correctly.

7.2.9 How to handle damaged batteries correctly



CAUTION!

Corrosion and burns from acid leakage if batteries are damaged

- Remove clothes that have been soiled by acid immediately.

After contact with skin:

- Immediately wash affected area with lots of water.

After contact with eyes:

- Immediately rinse eyes under running water for several minutes; consult a physician.

- Always wear safety goggles and appropriate safety clothing when handling damaged batteries.
- Place damaged batteries in an acid-resistant receptacle immediately after removing them.
- Only ever transport damaged batteries in an appropriate acid-resistant receptacle.
- Wash all objects that have come into contact with acid with lots of water.

Disposing of dead or damaged batteries correctly

Dead or damaged batteries can be given back to your provider or directly to Invacare.

8 Transport

8.1 Transport — General information



WARNING!

Risk of death or serious injury to the mobility device user and potentially any other nearby occupant of the vehicle, if a mobility device is secured using a 4-point tie-down system available from a third party supplier and the unladen weight of the mobility device exceeds the maximum weight for which the tie-down system is certified

- Make sure the weight of the mobility device does not exceed the weight for which the tie-down system is certified. Consult the tie-down manufacturer's documentation.
- If you are unsure how much your mobility device weighs, then you must have it weighed using calibrated scales.



CAUTION!

Risk of injury or material damage if a mobility device which is fitted with a tray is transported in a vehicle

- If a tray is fitted, always remove it before transporting the mobility device.



8.2 Transferring the mobility device to a vehicle



WARNING!

The mobility device is at risk of tipping over if it is transferred to a vehicle while the user is still seated in the mobility device

- Transfer the mobility device without the user whenever possible.
- If the mobility device with the user has to be transferred to a vehicle using a ramp, ensure that the ramp does not exceed the rated slope (refer to *11 Technical Data, page 103*).
- If the mobility device has to be transferred to a vehicle using a ramp that does exceed the rated slope (refer to *11 Technical Data, page 103*), a winch must then be used. An attendant can then safely monitor and assist the transfer process.
- Alternatively, a platform lift may be used.
- Ensure that the total weight of the mobility device including the user does not exceed the maximum permitted total weight for the ramp or platform lift.
- The mobility device should always be transferred to a vehicle with the backrest in an upright position, the seat lifter lowered and the seat tilt in the upright position (refer to *6.7 Driving up and down gradients, page 78*).



WARNING!

Risk of injury and damage to the mobility device

If the mobility device is to be transferred to a vehicle via a lift, when the remote is turned on, there is a risk that the device may act erratically and fall off the lift.

- Before transferring the mobility device via a lift, turn off the product and disconnect either the bus cable from the remote or the batteries from the system.

1. Drive or push your mobility device into the transport vehicle using a suitable ramp.

8.3 Use of the wheelchair as a seat in a vehicle



The following section does not apply to models or configurations which may not be used as a vehicle seat. These are identified by the following label on the mobility device:



ISO 7176-19



WARNING!

Risk of injury

Safety restraint devices must only be used when the wheelchair user's weight is 22 kg or more.

- When the user weight is lower than 22 kg, do not use the wheelchair as a seat in a vehicle.



CAUTION!

There is an injury hazard if a backrest which is not suitable for the transportation of passengers is used

- Angle-adjustable backrests which are manually adjusted using a self-arresting quick-disconnect are NOT approved for the transportation of passengers.



CAUTION!

There is a risk of injury if the wheelchair is not properly secured during use as a vehicle seat

- If possible, the user should always leave the wheelchair to use a vehicle seat and the safety belts provided with the vehicle.
- The wheelchair should always be anchored facing in the transport vehicle's intended direction of travel.
- The wheelchair must always be secured in accordance with the wheelchair and anchoring system manufacturers' operating manual.
- Always remove and secure any accessory parts fixed to the wheelchair such as chin controls or tables.
- If your wheelchair is equipped with an angle adjustable backrest, then it must be placed in an upright position.
- Fully lower elevated legrests, if fitted.
- Fully lower the seat lifter, if fitted.

**CAUTION!**

Risk of injury exists if a mobility device that is not equipped with leak-proof batteries is transported in a vehicle

- Only ever use leak-proof batteries.

**CAUTION!**

Risk of injury, if the batteries are not properly secured

- Secure the battery belt with the safety clip (refer to 8. *Special information about reassembly, page 96*).

**CAUTION!**

Risk of injury or damage to the mobility device or to the transporting vehicle, if the legrests are in a raised position while the mobility device is used as a vehicle seat

- Always completely lower height-adjustable legrests, if fitted.



In order to use a mobility device as a motor vehicle seat, it needs to be fitted with attachment points to enable anchoring in the motor vehicle. These accessories may be included in the standard scope of mobility device order and delivery in some countries (UK for example), but may also be obtained from Invacare as an option in other countries.

This mobility device complies with the requirements of ISO 7176-19 and may be used as a vehicle seat in connection with an anchoring system that has been checked and

approved in accordance with ISO 10542. The transporting vehicle must be professionally converted to anchor the mobility device. Contact your vehicle's manufacturer for more information.

The mobility device has undergone a crash test in which it was anchored in the transporting vehicle's direction of travel. Other configurations were not tested. The crash test dummy was secured using pelvic and upper body safety belts. Both types of safety belt should be used in order to minimize the risk of injuries to head or upper body.



Invacare tests with a 4-point tie-down system from Unwin Safety Systems.

- Contact Unwin for more information on how to obtain such a system for your country and vehicle type. For information on the curb weight of your mobility device, refer to 11 *Technical Data, page 103*

It is imperative that the mobility device is inspected by an authorized provider before being used again after being involved in a crash. Alterations to the mobility device anchoring points may not be carried out without the manufacturer's permission.

8.3.1 How the wheelchair is anchored in a vehicle

The mobility device is fitted with four tie-down points. Snap hooks or belt loops can be used for fixation. If the wheelchair can be used as a vehicle seat, these tie-down points are labelled with the symbol shown on the right.



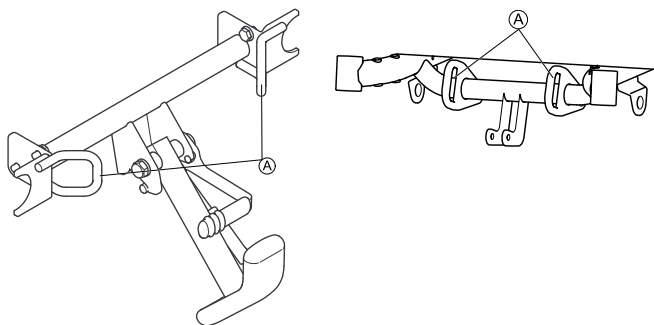

Front (with curb climber) Front (without curb climber)

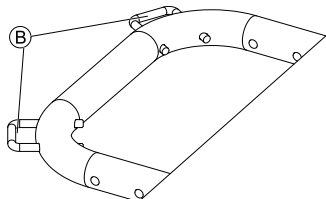

Fig. 8-1 Rear

1. Secure the wheelchair at the front **A** and at the rear **B** with the tie-down system belts. The curb climber does not have to be removed.
2. Secure the wheelchair by tensioning the belts in accordance with the tie-down system manufacturer's instruction manual.

8.3.2 How the user is secured within the mobility device



CAUTION!

Risk of injury if the user is not properly secured within the mobility device

- Even if the mobility device is fitted with a posture belt, this is no substitute for a proper safety belt which complies with ISO 10542 in the transport vehicle. Always use the safety belt installed in the transport vehicle.
- Safety belts must be in contact with the user's body. They must not be held at a distance from the user's body using parts of the mobility device such as armrests or wheels.
- Safety belts must be pulled as tightly as possible without causing the user discomfort.
- Safety belts must not be positioned while twisted.
- Ensure that the third seat belt anchorage point is not fixed directly to the vehicle floor, but to one of the vehicle uprights.

**CAUTION!**

Risk of injury during use of the mobility device as a vehicle seat if a headrest is wrongly adjusted or not installed

This can cause the neck to be hyperextended during collisions.

- A headrest must be installed. The headrest optionally supplied for this mobility device by Invacare is perfectly suitable for use during transport.
- The headrest must be adjusted to the user's ear height.

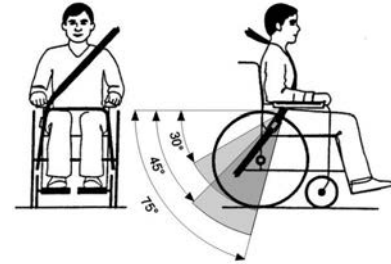

The pelvic belt should be positioned in the area between the user's pelvis and thighs so that it is unobstructed and not too loose. The ideal angle of the pelvic belt to the horizontal is between 45° and 75°. The maximum permissible angle is between 30° and 75°. The angle should never be less than 30°!

Seat belts may not be held at a distance from the user's body using parts of the mobility device such as armrests or wheels.

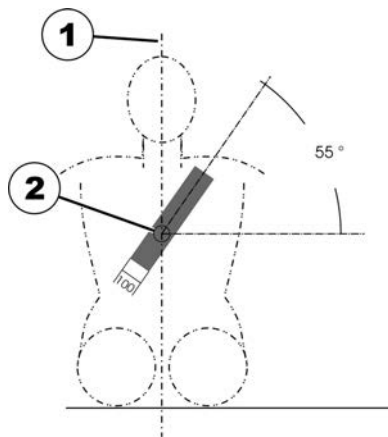

The safety belt installed in the transporting vehicle should be applied as shown in the illustration above.

- 1) Center line of the body
- 2) Center of the sternum

8.4 Transporting the mobility device without occupant



CAUTION!

Risk of injury

– If you are unable to fasten your mobility device securely in a transport vehicle, Invacare recommends that you do not transport it.

Your mobility device may be transported without restrictions, whether by road, rail or by air. Individual transport companies have, however, guidelines which can possibly

restrict or forbid certain transport procedures. Please ask the transport company regarding each individual case.

- Before transporting your mobility device, make sure the motors are engaged and that the remote is switched off. Invacare strongly recommends that you additionally disconnect or remove the batteries. Refer to Removing the batteries.
- Invacare strongly recommends securing the mobility device to the floor of the transporting vehicle.

8.4.1 Preparing the wheelchair for transport without occupant

Please proceed as follows to prepare the wheelchair for transport:

1. Remove legrests (please refer to the chapter concerning legrests)
2. Remove the battery case (not possible for versions with rear shroud and fixed batteries)
3. Tip the backrest forwards
4. Remove the seat if necessary (not possible for versions with rear shroud and fixed batteries)

The wheelchair is reassembled in reverse order to the above.

8.4.2 Removing the battery boxes

(not possible for versions with rear shroud and fixed batteries)

1.

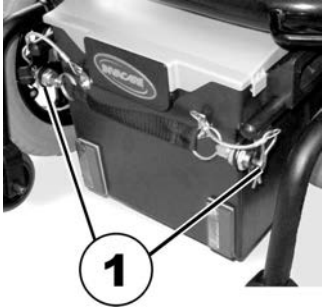

Remove the safety clip for the battery belt (1).

2.

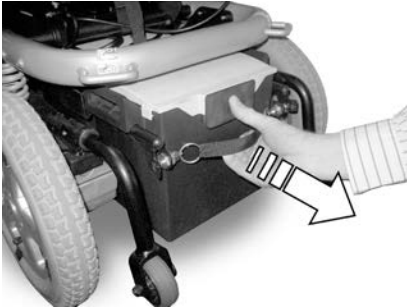

Pull the rear battery box backwards using the belt. The locking system opens automatically when doing so.

3.

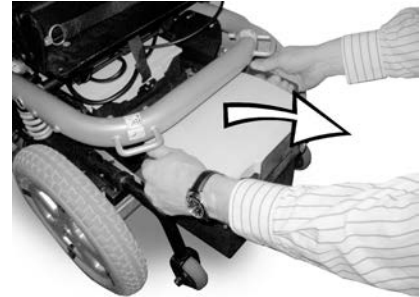

Pull the battery boxes out using the side handles.

4.

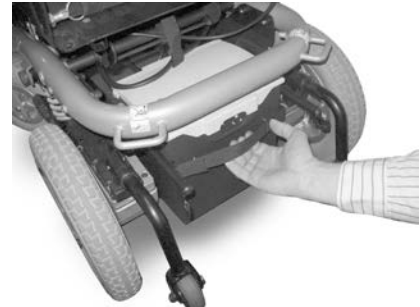

Pull the front battery box backwards using the belt and pull it out using the handles.

8.4.3 Removing the seat

(not possible for versions with lifter)

! Risk of damage to wheelchair if the seat cannot be folded up or forwards without collision

- Remove legrests first.
- Ensure that the legrest attachments do not hinder the seat when folding up. If necessary, vary the seat tilting.

1.



Unlock the seat (the unlocking belt is located under the seat at the rear).

2.

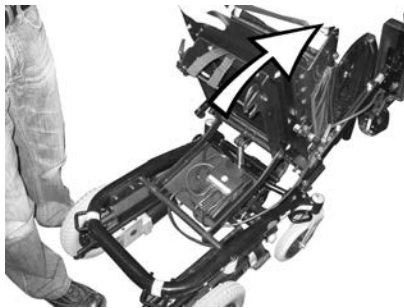

Fold the seat upwards.

3.



Pull the remote cable plug out of the electronics system.

4.



Remove the seat upwards. Depending on the type, the seat can weigh between 16 and 23 kg. Get the help of the second person if the seat is too heavy to lift alone.

8.4.4 Reassembling the wheelchair

The wheelchair is reassembled in reverse order to the above.

8.4.5 Special information about reassembly

(Steps 6 – 8 not possible for versions with rear shroud and fixed batteries)

1.



When reassembling, ensure that the seat guide forks (1) are placed precisely on the stay bar in the front area.

2.



Ensure that there are no cables in the area around the rear stay bar (1) to avoid cable damage.

3.



Guide the remote cable under the seat support and connect it to the electronics system.

4. Fold the seat down. It must audibly engage.



CAUTION!

Injury hazard if the seat locking system does not completely engage

– Make absolutely sure that the locking system is correctly engaged. To do this, pull the seat upwards. It must be completely immobile.

9 Maintenance

9.1 Maintenance introduction

The term “Maintenance” means any task performed to ensure that a medical device is in good working order and ready for use as intended. Maintenance encompasses different areas, such as everyday care and cleaning, inspection checks, repair tasks and refurbishment.



Have your vehicle checked once a year by an authorized Invacare provider in order to maintain its driving safety and roadworthiness.

9.2 Cleaning the mobility device

When cleaning the mobility device, pay attention to the following points:

- Only use a damp cloth and gentle detergent.
- Do not use any abrasive or scouring agents.
- Do not subject the electronic components to any direct contact with water.

9.3.1 Before each use of the mobility device

Item	Inspection check	If inspection is not passed
Signal horn	Check for correct function.	Contact your provider.
Lighting system	Check that all lights, such as turn indicators, head lamps and tail lights, are functioning correctly.	Contact your provider.

- Do not use any high-pressure cleaning devices.

Disinfection

Spray or wipe disinfection using a tested and recognised product is permitted. A list of the current permitted disinfectants is available from the Robert Koch Institute at <http://www.rki.de>.

9.3 Inspection checks

The following table lists inspection checks that should be performed by the user and their intervals. If the mobility device fails to pass one of the inspection checks, refer to the chapter indicated or contact your authorized Invacare provider. A more comprehensive list of inspection checks and instructions for maintenance work can be found in the service manual for this device, which can be obtained from Invacare. That manual, however, is intended to be used by trained and authorized service technicians, and describes tasks which are not intended to be performed by the user.

Item	Inspection check	If inspection is not passed
Battery box locking system	Check to ensure that the battery box locking system is functioning correctly. Locking pins must be completely engaged in the holes provided for them (see chapter 8.4 <i>Transporting the mobility device without occupant, page 92</i>).	Contact your provider.
Batteries	Make sure the batteries are charged. See the user manual provided with your remote for a description of the battery charge indicator.	Charge the batteries (see chapter 7.2.3 <i>How to charge the batteries, page 83</i>).

9.3.2 Weekly

Item	Inspection check	If inspection is not passed
Armrests/side parts	Check that armrests are firmly attached in their holders and do not wobble.	Tighten the screw or clamping lever that holds the armrest (see chapter 5.2 <i>Adjustment possibility for remote, page 31</i>). Contact your provider.
Tires (pneumatic)	Check that the tires are undamaged.	Contact your provider.
	Check that the tires are inflated to the correct pressure.	Inflate the tire to the correct pressure (see chapter 9.4 <i>Wheels and tires, page 99</i> and 11 <i>Technical Data, page 103</i>).
Tires (puncture-proof)	Check that the tires are undamaged.	Contact your provider.
Antitippers	Check that antitippers are firmly attached and do not wobble. Check that the spring clips of the antitippers are in good order and secure the antitippers correctly.	Contact your provider.

9.3.3 Monthly

Item	Inspection check	If inspection is not passed
All upholstered parts	Check for damage and wear.	Contact your provider.
Removable legrests	Check whether the legrests can be fixed securely and whether the loosening mechanism is properly operable.	Contact your provider.
	Check that all adjustment options function properly.	Contact your provider.
Casters	Check that casters rotate and swivel freely.	Contact your provider.
Drive wheels	Check that the drive wheels rotate without wobbling. It is easiest to have someone stand behind the mobility device and observe the drive wheels as you drive away from them to do this.	Contact your provider.
Electronics and connectors	Check all cables for damage and all connecting plugs for snug fit.	Contact your provider.

9.4 Wheels and tires

Dealing with wheel damages

In case of having a damaged wheel, contact your provider. Because of safety reasons do not have the wheel repaired by yourself or by not authorized persons.

Dealing with pneumatic tires



Risk of damage to tire and rim

Never drive with too low tire pressure, this could result in damage to tire.

If tire pressure is exceeded rim could be damaged.

– Inflate tires to recommended pressure.



Use tire gauge to check pressure.

Check weekly that the tires are inflated to the correct pressure, see chapter 9.3 *Inspection checks, page 97*.

For recommended tire pressure see inscription on tire/rim or contact Invacare. Compare table below for conversion.

psi	bar
22	1.5
23	1.6
25	1.7

psi	bar
26	1.8
28	1.9
29	2.0
30	2.1
32	2.2
33	2.3
35	2.4
36	2.5
38	2.6
39	2.7
41	2.8
44	3.0

9.5 Short-term storage

In case a serious fault is detected, a number of safety mechanisms are built into your mobility device and will protect it. The power module prevents your mobility device from driving.

When the mobility device is in such a condition and while waiting for repair:

1. Switch off power.
2. Disconnect the batteries.
Depending on the mobility device model, you can either remove the battery packs or disconnect the batteries from the power module. Refer to the corresponding chapter about disconnecting the batteries.
3. Contact your provider.

9.6 Long-term storage

In case your mobility device is not used for a longer period of time, you need to prepare it for storage to ensure a longer life for your mobility device and batteries.

Storing mobility device and batteries

- We recommend to store the mobility device at a temperature of 15° C, avoid hot and cold extremes when storing to ensure a long service life of the product and batteries.
- The components are tested and approved for greater temperature ranges as detailed below:
 - Allowable temperature range to store the mobility device is -40° up to 65° C.
 - Allowable temperature range to store batteries is -25° up to 65° C.
- Even not being used, batteries discharge themselves. Best practice is to disconnect the battery supply from the power module if storing the mobility device longer than two weeks. Depending on the mobility device model, you can either remove the battery packs or disconnect the batteries from the power module. Refer to the corresponding chapter about disconnecting the batteries. If in doubt which cable to disconnect, contact your provider.

- Batteries should always be fully charged before storing.
- If storing the mobility device longer than four weeks, check the batteries once a month and recharge as needed (before gauge reads half full) to avoid damage.
- Store in a dry, well-ventilated environment protected from outer influences.
- Slightly overinflate pneumatic tires.
- Position the mobility device on flooring that is not discolored by contact with tire rubber.

Preparing mobility device for use

- Re-connect the battery supply to the power module.
- The batteries must be charged before use.
- Have the mobility device checked by an authorized Invacare provider.

10 After Use

10.1 Reconditioning

The product is suitable for reuse. To recondition the product for a new user, carry out the following actions:

- Cleaning and disinfection. Refer to *9 Maintenance, page 97*.
- Inspection according to service plan. Consult service instructions, available from Invacare.
- Adaptation to the user. Refer to *5 Setup, page 30*.

10.2 Disposal

- The equipment wrapping is potentially recyclable.
- The metal parts are used for scrap metal recycling.
- The plastic parts are used for plastic recycling.
- Electric components and printed circuit boards are disposed of as electronic scrap.
- Exhausted or damaged batteries can be returned to your medical equipment supplier or Invacare.
- Disposal must be carried out in accordance with the respective national legal provisions.
- Ask your city or district council for details of the local waste management companies.

11 Technical Data

11.1 Technical specifications

The technical information provided hereafter applies to a standard configuration or represents maximum achievable values. These can change if accessories are added. The precise changes to these values are detailed in the sections for the respective accessories.

 Note that in some cases the measured values may vary up to ± 10 mm.

Permissible operating and storage conditions	
Temperature range for operation according to ISO 7176-9:	<ul style="list-style-type: none"> -25° ... +50 °C
Recommended storage temperature:	<ul style="list-style-type: none"> 15 °C
Temperature range for storage according to ISO 7176-9:	<ul style="list-style-type: none"> -25° ... +65 °C with batteries -40° ... +65 °C without batteries

Electrical system	
Motors	<ul style="list-style-type: none"> 2 x 250 W 2 x 340 W (Heavy Duty)
Batteries	<ul style="list-style-type: none"> 2 x 12 V/50 Ah (C20) leakproof/AGM 2 x 12 V/40 Ah (C20) leakproof/gel 2 x 12 V/50 Ah (C20) leakproof/gel (version with rear shroud and fixed batteries)
Main fuse	<ul style="list-style-type: none"> 50 A strip fuse for each battery box
Degree of protection	IPX4 ¹

Charging device	
Output current	<ul style="list-style-type: none"> • 8 A ± 8 % • 10 A
Output voltage	<ul style="list-style-type: none"> • 24 V nominal (12 cells)

Drive wheel tires	
Tire type	<ul style="list-style-type: none"> • 317 (12½" x 2¼") pneumatic or puncture-proof
Tire pressure	<p>The recommended maximum tire pressure in bar or kpa is marked on the side wall of the tire or the rim. If more than one value is listed, the lower one in the corresponding units applies.</p> <p>(Tolerance = -0.3 bar, 1 bar = 100 kpa)</p>

Caster tires	
Tire type	<ul style="list-style-type: none"> • 200x45 puncture-proof (not for Heavy Duty)
Tire type	<ul style="list-style-type: none"> • 230x60 (2.80/2.50-4) pneumatic <p>The recommended maximum tire pressure in bar or kpa is marked on the side wall of the tire or the rim. If more than one value is listed, the lower one in the corresponding units applies.(Tolerance = -0.3 bar, 1 bar = 100 kpa)</p>
Tire type	<ul style="list-style-type: none"> • 230x60 (2.80/2.50-4) puncture-proof

Driving characteristics	
Speed	<ul style="list-style-type: none"> • 3 km/h • 6 km/h • 10km/h
Min. braking distance	<ul style="list-style-type: none"> • 500 mm (3 km/h) • 1000 mm (6 km/h) • 2100 mm (10 km/h)

Driving characteristics	
Rated slope ²	
without lifter	<ul style="list-style-type: none"> • 10° (18 %) according to manufacturer's specifications with 130 kg payload, 4° seat angle, 20° backrest angle
with lifter	<ul style="list-style-type: none"> • 6° (10.5 %) according to manufacturer's specifications with 130 kg payload, 4° seat angle, 20° backrest angle
Max. climbable obstacle height	<ul style="list-style-type: none"> • 60 mm (100 mm with curb climber)
Turning diameter	<ul style="list-style-type: none"> • 1600 mm (without lifter) • 1630 mm (with lifter)
Turning width	<ul style="list-style-type: none"> • 1250 mm
Pivot width	<ul style="list-style-type: none"> • 1450 mm • 1600 mm (Heavy Duty)
Drive range in accordance with ISO 7176-4 ³	<ul style="list-style-type: none"> • 30 km (50 Ah batteries) • 25 km (40 Ah batteries)

Dimensions according to ISO 7176-15	Seat type		
	Firm seat	Flex 2 / Max	Modulite
Total height (without lifter)	<ul style="list-style-type: none"> • 1050 mm 	<ul style="list-style-type: none"> • 980 mm • 1050 - 1100 mm (Max) 	<ul style="list-style-type: none"> • 930 mm (one piece seat plate) • 960 - 1060 mm (telescopic seat frame, moving the backrest plate)
Total height (with lifter)	<ul style="list-style-type: none"> • 1060 - 1360 mm 	<ul style="list-style-type: none"> • 1010 - 1310 mm 	<ul style="list-style-type: none"> • 930 mm (one piece seat plate)

Dimensions according to ISO 7176-15	Seat type		
	Firm seat	Flex 2 / Max	Modulite
		<ul style="list-style-type: none"> 1080 - 1430 mm (Max) 	<ul style="list-style-type: none"> 960 - 1060 mm (telescopic seat frame, moving the backrest plate)
Max. total width (component with widest point in parentheses)	<ul style="list-style-type: none"> 590 mm (caster wheel 200x45) 600 mm (measured from outer edge of armrests at seat width 39) 620 mm (caster wheel 230x60) 640 mm (measured from outer edge of armrests at seat width 43) 	<ul style="list-style-type: none"> 600 mm (measured from outer edge of armrests at seat width 39) 620 mm (caster wheel 230x60) 640 mm (measured from outer edge of armrests at seat width 44) 690 mm (measured from outer edge of armrests at seat width 49) 790 mm (Max) 	<ul style="list-style-type: none"> 620 mm (front wheel 230x60) 640 mm (measured from outer edge of armrests at seat width 48) 690 mm (measured from outer edge of armrests at seat width 53)
Total length (incl. standard legrests)	<ul style="list-style-type: none"> 1160 mm (without lifter) 1210 mm (with lifter) 		<ul style="list-style-type: none"> 1160 mm (without lifter) 1210 mm (with lifter)
Total length (without standard legrests)	<ul style="list-style-type: none"> 820 mm (without lifter) 840 mm (with lifter) 		<ul style="list-style-type: none"> 820 mm (without lifter) 840 mm (with lifter)
Stowage length	<ul style="list-style-type: none"> 755 mm 	<ul style="list-style-type: none"> 940 mm 	<ul style="list-style-type: none"> 800 mm
Stowage width	<ul style="list-style-type: none"> 625 mm 	<ul style="list-style-type: none"> 735 mm 	<ul style="list-style-type: none"> 620 mm
Stowage height	<ul style="list-style-type: none"> 530 mm 	<ul style="list-style-type: none"> 835 mm 	<ul style="list-style-type: none"> 715 mm

Dimensions according to ISO 7176-15	Seat type		
	Firm seat	Flex 2 / Max	Modulite
Ground clearance	<ul style="list-style-type: none"> w/o curb climber: 58 mm with curb climber: 33 mm 		<ul style="list-style-type: none"> 60 mm
Seat height ⁴	<ul style="list-style-type: none"> 460 mm (without lifter) 480 - 780 mm (with lifter) 	<ul style="list-style-type: none"> 470 mm (without lifter) 490 - 790 mm (with lifter) 	<ul style="list-style-type: none"> 450 mm (without lifter) 450 - 750 mm (with lifter)
Seat width (armrest adjustment range in parentheses)	<ul style="list-style-type: none"> 430 mm (440 - 480 mm⁵) 390 mm (400 - 440 mm⁵) 330 mm (340 - 370 mm⁵) 	<ul style="list-style-type: none"> 390 mm (390 mm) 440 mm (440 - 480 mm⁵) 490 mm (490 - 530 mm⁵) 560 mm (560 - 600 mm⁵) (Max) 	<ul style="list-style-type: none"> 380 mm (380 - 430 mm⁵) 430 mm (430 - 480 mm⁵) 480 mm (480 - 530 mm⁵) 530 mm (530 - 580 mm⁵)
Seat depth	<ul style="list-style-type: none"> 300/330/350/380/440/480 mm 	<ul style="list-style-type: none"> 430 - 510 mm 510 - 580 mm (Max) 	<ul style="list-style-type: none"> 410 - 510 mm
Backrest height ⁴	<ul style="list-style-type: none"> 430/570 mm 	<ul style="list-style-type: none"> 560 mm 630 - 680 mm (Max) 	<ul style="list-style-type: none"> 480/540 mm (sling back) 560 - 660 mm (telescopic seat frame, moving the backrest plate)
Seat cushion thickness	<ul style="list-style-type: none"> 70 mm 	<ul style="list-style-type: none"> 125 mm 	<ul style="list-style-type: none"> 50/75/100 mm
Backrest angle ⁶	<ul style="list-style-type: none"> 90° ... 120° (electrical) 90° ... 112° (manual) 	<ul style="list-style-type: none"> 90° - 120° 	
Armrest height	<ul style="list-style-type: none"> 190 - 320 mm 	<ul style="list-style-type: none"> 240 - 310/260 - 340 mm 300 - 410 mm (Max) 	<ul style="list-style-type: none"> 245 - 310/295 - 360 mm (telescopic seat frame with T-armrest) 275 - 340/325 - 390 mm (one piece seat plate with T-armrest)

Dimensions according to ISO 7176–15	Seat type		
	Firm seat	Flex 2 / Max	Modulite
Armrest depth ⁷	• 375 mm		• 325 mm
Horizontal location of axle ⁸	• 35 mm	• 122 mm	• 140 mm
Seat angle, electronic adjustment	<ul style="list-style-type: none"> • 0° ... +20° (without lifter) • 0° ... +28° (with lifter)⁶ 		<ul style="list-style-type: none"> • 0° ... +20° (without lifter) • 0° ... +30° (with center of gravity displacement)⁶
Seat angle, manual adjustment	• 0° ... +20°		

Footrests and legrests		Seat type		
Type		Firm seat	Flex 2 / Max	Modulite
Junior 70	Length	• 200 - 250 mm	-	-
	Angle	• 70°	-	-
Mini 90	Length	• 200 - 250 mm	-	-
	Angle	• 90°	-	-
Standard 70	Length	• 320 - 390 mm	-	-
	Angle	• 70°	-	-
Standard 80 (not for Heavy Duty)	Length	• 350 - 450 mm		
	Angle	• 80°		
Vari F	Length	• 290 - 460 mm		
	Angle	• 70° – 0°		

Footrests and legrests		Seat type		
Type		Firm seat	Flex 2 / Max	Modulite
Vari A	Length Angle	<ul style="list-style-type: none"> • 290 - 460 mm • 70° – 0° 		
ADE (electric)	Length Angle	<ul style="list-style-type: none"> • 290 - 460 mm • 80° – 0° 		
Angle-adjustable (manual)	Length Angle	<ul style="list-style-type: none"> • 340 - 440 mm • 50 - 65° 	- -	- -
Height-adjustable (manual)	Length Angle	<ul style="list-style-type: none"> • 350 - 450 mm • 70° – 0° 		

Weight ⁹	Firm seat	Flex 2 / Max	Modulite
Curb weight (without lifter)	• 91 kg	• 94 kg	• 98 kg
Curb weight (with lifter)	• 123 kg	• 126 kg	• 130 kg

Component weights	Firm seat / Flex 2 / Max / Modulite
Seat unit	• approx. 23 kg
Chassis	• approx. 45 kg
Batteries	• approx. 15 kg per battery

Payload	Firm seat	Flex 2 / Max / Modulite
Max. payload	<ul style="list-style-type: none"> • 60 kg (seat depth 30) • 65 kg (seat depth 33) • 70 kg (seat depth 35) • 75 kg (seat depth 38) • 130 kg (seat depth 44) • 130 kg (seat depth 48) 	<ul style="list-style-type: none"> • 130 kg • 160 kg (Heavy Duty)

Axle loads	
Max. front axle load	<ul style="list-style-type: none"> • 110 kg • 135 kg (Heavy Duty)
Max. rear axle load	<ul style="list-style-type: none"> • 140 kg • 160 kg (Heavy Duty)

- 1 IPX4 classification means that the electrical system is protected against spray water.
- 2 Static stability according to ISO 7176-1 = 9° (15.8 %)
Dynamic stability according to ISO 7176-2 = 6° (10.5 %)
- 3 Note: The drive range of a mobility device is strongly influenced by external factors, such as the speed setting of the wheelchair, the charging state of the batteries, surrounding temperature, local topography, road surface characteristics, tire pressure, weight of user, drive style and use of batteries for lighting, servos etc.
The specified values are theoretical maximum achievable values measured according to ISO 7176-4.
- 4 Measured without seat cushion
- 5 Width adjustable for side panel adjustment
- 6 As soon as the lifter is raised above a certain point you can adjust the seat and backrest angles only at a combined total of max. 15°.

- 7 Distance between backrest reference plane and most forward part of armrest assembly
- 8 Horizontal distance of wheel axle from intersection of loaded seat and backrest reference planes
- 9 The actual curb weight depends on the fittings your mobility device has been supplied with. Every Invacare mobility device is weighed when leaving the works. Refer to the nameplate for the curb weight (including batteries) measured.

12 Service

12.1 Inspections performed

It is confirmed by stamp and signature that all jobs listed in the inspection schedule of the service and repair instructions have been properly performed. The list of the inspection jobs to be performed can be found in the service manual which is available through Invacare.

Delivery Inspection	1st Annual Inspection
Stamp of authorized provider / Date / Signature	Stamp of authorized provider / Date / Signature
2nd Annual Inspection	3rd Annual Inspection

Stamp of authorized provider / Date / Signature	Stamp of authorized provider / Date / Signature
4th Annual Inspection	5th Annual Inspection
Stamp of authorized provider / Date / Signature	Stamp of authorized provider / Date / Signature

Invacare Sales Companies

Australia:

Invacare Australia PTY. Ltd.
1 Lenton Place, North Rocks NSW
2151

Australia

Phone: 1800 460 460

Fax: 1800 814 367

orders@invacare.com.au

www.invacare.com.au

United Kingdom:

Invacare Limited

Pencoed Technology Park, Pencoed

Bridgend CF35 5AQ

Tel: (44) (0) 1656 776 222

Fax: (44) (0) 1656 776 220

uk@invacare.com

www.invacare.co.uk

Canada:

Invacare Canada LP
570 Matheson Blvd E. Unit 8
Mississauga Ontario

L4Z 4G4, Canada

Phone: (905) 890 8300

Fax: (905) 501 4336

Eastern Europe, Middle East & CIS:

Invacare EU Export

Kleiststraße 49

D-32457 Porta Westfalica / Germany

Tel: (49) (0)57 31 754 540

Fax: (49) (0)57 31 754 541

webinfo-eu-export@invacare.com

www.invacare-eu-export.com

Ireland:

Invacare Ireland Ltd,
Unit 5 Seatown Business Campus
Seatown Road, Swords, County Dublin

Tel : (353) 1 810 7084

Fax: (353) 1 810 7085

ireland@invacare.com

www.invacare.ie

New Zealand:

Invacare New Zealand Ltd
4 Westfield Place, Mt Wellington 1060
New Zealand

Phone: 0800 468 222

Fax: 0800 807 788

sales@invacare.co.nz

www.invacare.co.nz



Manufacturer:

Invacare Deutschland GmbH

Kleiststraße 49

D-32457 Porta Westfalica

Germany

1528224-T 2017-07-12



Making Life's Experiences Possible®



Yes, you can.®